

## Pillar and wall-mounted slewing jibs and cranes

Workplace efficiency improvement with the Demag crane range



## System components and installations

As a pioneer in overhead materials handling, we have been developing and manufacturing cranes and hoists for more than 190 years. Thanks to the system philosophy, all products and components are designed in such a way that they can be combined to create a unique scope of applications, ranging from simple hoists to complex system solutions.

State-of-the-art material-flow solutions make it possible to reduce storage and transport costs and cut delivery times in companies of all sizes – from small workshops to major industrial enterprises. Demag slewing jibs and cranes can also make a crucial contribution towards making the work place more ergonomic.





We offer holistic solutions at a high level of cost effectiveness – while maximising operating safety for the user, the installation and the load.

By applying the highest standards of innovation and quality, we are able to maximise added value for the customer.

Demag slewing jibs and cranes are technologically sophisticated products and are ideal for workplace improvement in a wide range of applications.



## Switch to improved productivity and ergonomics

The manual handling, combining and moving of relatively light loads is often both time-consuming and an ergonomic burden for employees. Together with a wide selection of hoist units, slewing jibs and cranes installed direct at the workplace enable all types of workpieces to be lifted and transported quickly and deposited gently and precisely.

In this way, setting-up and idle times are considerably reduced and periods of waiting for workshop cranes to become available can be completely eliminated.





### Precise and smooth positioning

Working with sensitive products, tools and machinery often requires very careful handling of the parts. Smooth lifting and lowering motions as well as precise positioning with pillar-mounted slewing jibs and pillar and wall-mounted slewing cranes enable sensitive and valuable loads to be handled gently and rejects caused by impacts, sudden jolts and hard landings to be avoided. This results in smooth and efficient operating sequences and, in consequence, greater productivity at individual workplaces. At the same time, the use of slewing jibs and cranes relieves workers of the physical burden and reduces the risk of accidents and injuries when heavy or awkward parts are handled.







### Optimum support

Pillar-mounted slewing jibs and pillar and wall-mounted slewing cranes ideally supplement all materials handling installations throughout the in-house material flow. They provide handling performance at machine tools and assembly stations, as well as in outdoor storage yards and on loading ramps.

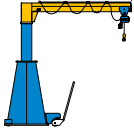
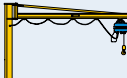
These cranes can be installed with ease wherever other materials handling equipment cannot be used for structural reasons or because of the available space. They can also be integrated in machinery and other installations.

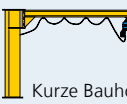
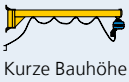
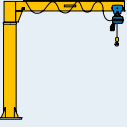

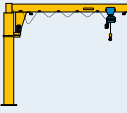
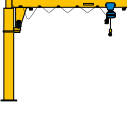
# The right crane solution for every application

Max. load capacity [kg]	Pillar-mounted slewing cranes			Wall-mounted slewing jibs		
	Type	Outreach up to [m]	Slewing range	Type	Outreach up to [m]	Slewing range
500	D-MOS 	5	∞ 360°			
	KBK Standard 	7	~ 300°	KBK Standard 	7	~ 270°
1,000	Kurze Bauhöhe 			Kurze Bauhöhe 		
	D-GS 	7	∞ 360°			
2,000	D-AS 	10	~ 270°	D-AW 	10	~ 180°
5,000	D-TS 	7	∞ 360°			
10,000	D-MS 	12	∞ 360°	D-GW 	12	~ 180°

The crane types shown on the following pages are designed for indoor operation as standard. Designs

for outdoor operation require additional protection features, which can be found on page 18.

# D-MOS mobile pillar-mounted slewing cranes



		Operating range			
		Outreach [m]			
		2	3	4	5
SWL [kg]	125				
	250				
	315				
	400				
	500				

Mobile pillar-mounted slewing cranes are ideally suited for workplaces that are subject to frequent change, since the crane can be simply relocated together with the workplace. In this way, the position of the crane can be precisely matched to the required operating sequences. D-MOS cranes are also a preferred choice for maintenance, repair and conversion work.

- Classification according to DIN 15018 H2B2
- The compact slewing unit design ensures minimum approach dimensions
- Can be easily relocated by means of a forklift or workshop crane
- Aligned at the operating location by means of four adjusting screws integrated in the crane base
- Fitted with Demag chain hoist as standard
- I-beam profile jib

## Options

- Pillar extension for larger hook paths
- Manually operated trolley to move the crane without the need for any accessories
- Low-maintenance flat-cable festoon power supply
- Control travelling separately along the jib

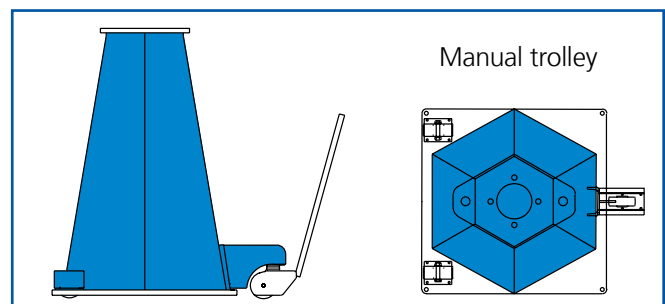

# KBK pillar-mounted slewing jibs

SWL [kg]	Operating range					
	Outreach [m]					
	2	3	4	5	6	7
80						
125						
250						
500						
1,000						



KBK slewing jibs feature high load capacities and outreach in relation to their deadweight. The low weight enables the jib to be moved easily and the use of KBK hollow section rail as the crane girder provides for very low travel forces.

- Classification according to DIN 15018 H2B3
- Fitted with Demag chain hoist as standard
- Hollow-section jib.
- Hammerhead pillar facilitates large slewing angle

## Options

- Anchor bolt set and template for fixing to foundations
- Anchor bolts
- Other pillar heights and/or pedestal for larger hook paths
- Slewing motion limit stops
- Locking arrangement for the jib
- Equipment for outdoor operation.

### KBK pillar and wall-mounted slewing jibs are also available in low-headroom design

The low headroom dimension results in a lifting height gain of 290 mm compared to the standard design. Whether for low-headroom applications, modernisation measures or changes in the use of the building, our "short" units are the perfect crane solution in many cases.



# KBK wall-mounted slewing jibs



SWL [kg]	Operating range					
	Outreach [m]					
	2	3	4	5	6	7
80	✓	✓	✓	✓	✓	✓
125	✓	✓	✓	✓	✓	✓
250	✓	✓	✓	✓	✓	✓
500	✓	✓	✓	✓	✓	✗
1,000	✓	✓	✓	✓	✗	✗

Wall-mounted slewing jibs do not take up any floor space. They are mounted on load-bearing concrete walls, pillars, or existing machinery and installations. They are particularly easy to install, since the bracket is supplied ready to be fitted as a unit, which eliminates any complicated alignment work. KBK wall-mounted slewing jibs are suitable for a load range up to 1,000 kg.

### Options

- Classification according to DIN 15018 H2B3
- Fitted with Demag chain hoist as standard
- Hollow-section jib

- Pillar bracket
- Slewing motion limit stops
- Locking arrangement for the jib
- Equipment for outdoor operation.

Operating range for low-headroom units	
SWL [kg]	Outreach [mm]
80	up to 3,860
125	up to 3,060
250	up to 2,260
500	up to 1,560

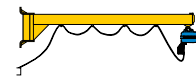
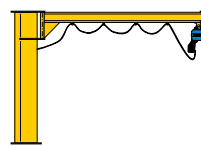

# KBK pillar-mounted slewing crane with two jibs

1st jib* SWL (kg) x outreach (m)	2nd jib* SWL (kg) x outreach (m)	Possible combinations			
200 x 3	200 x 2	A	B	C	D
250 x 2	160 x 3				
315 x 2	160 x 2				
400 x 2	125 x 2				
125 x 4	125 x 4	A	B	C	D
160 x 3	250 x 4				
200 x 3	250 x 3				
250 x 3	250 x 2				
315 x 2					
315 x 3	125 x 3				
500 x 2					
125 x 6	200 x 6	A	B	C	-
	400 x 5				
	500 x 4				
	630 x 3				
160 x 6	160 x 6	A	B	C	-
	250 x 5				
	400 x 4				
	500 x 3				
200 x 6	200 x 5	A	B	C	-
	400 x 3				
250 x 5	250 x 5	A	B	C	-
	315 x 4				
400 x 5	400 x 3	A	B	C	-
	200 x 5				
500 x 5	250 x 4	A	B	C	-
	315 x 3				
500 x 4	160 x 4	A	B	C	-
	250 x 3				
500 x 3	200 x 4	A	B	C	-
	315 x 3				
160 x 7	200 x 7	A	B	C	-
	400 x 6				
	800 x 5				
315 x 6	200 x 7	A	B	C	-
	250 x 6				
400 x 5	800 x 5	A	B	C	-
	800 x 4				
500 x 5	500 x 5	A	B	C	-
	630 x 4				
800 x 5	200 x 5	A	B	C	-
	125 x 5				
1,000 x 4	200 x 4	A	B	C	-
	250 x 3				
1,000 x 3	500 x 3	A	B	C	-
	315 x 4				

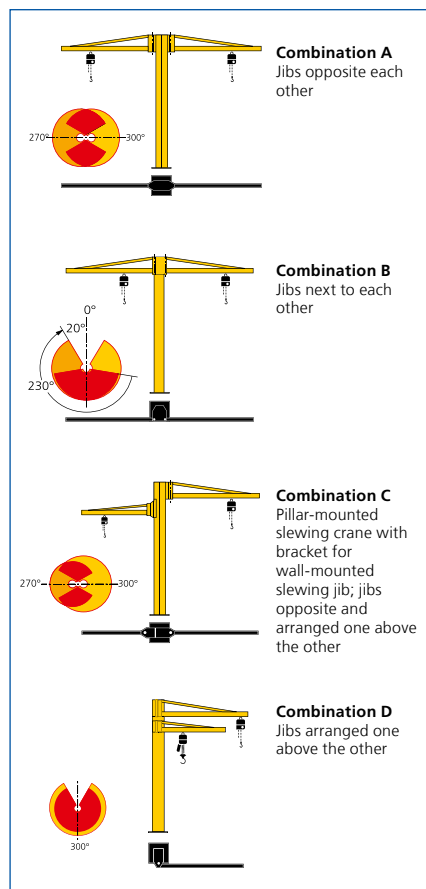

KBK pillar-mounted slewing cranes with two jibs are highly effective solutions that take up just as much floor space as a crane with a single slewing jib. Four different jib arrangements are available for the perfect workplace design, allowing individually planned working procedures to be streamlined.

- Classification according to DIN 15018 H2B3
- Fitted with Demag chain hoists as standard
- Hollow-section jib
- Hammerhead pillar facilitates large slewing angle

## Options

- Anchor bolt set and template for fixing to foundations
- Anchor bolts
- Other pillar heights and/or pedestal for larger hook paths
- Slewing motion limit stops
- Locking arrangement for the jib

\* Maximum available jib combinations. Smaller loads and outreaches can be selected per jib.

## D-GS pillar-mounted slewing cranes



SWL [kg]	Operating range					
	Outreach [m]					
	2	3	4	5	6	7
80	Operating	Operating	Operating	Operating	Operating	Operating
125	Operating	Operating	Operating	Operating	Operating	Operating
250	Operating	Operating	Operating	Operating	Operating	Limit
500	Operating	Operating	Operating	Limit	Limit	Limit
1,000	Operating	Limit	Limit	Limit	Limit	Limit

Pillar-mounted slewing cranes offer a significant advantage wherever movement of the jib is not inhibited by walls, columns or similar obstacles: the slewing range covers  $n \times 360^\circ$ . D-GS pillar-mounted slewing cranes for loads weighing up to 1,000 kg feature particularly low headroom and compact dimensions. They are ideally suited wherever maximum hook paths are required and only limited headroom is available.

- Classification according to DIN 15018 H2B2
- Fitted with Demag chain hoist as standard
- I-beam profile jib
- Round pillar

### Options

- Anchor bolt set and template for fixing to foundations
- TOP anchor attachment
- KOMPAKT anchor attachment
- Anchor bolts
- Other pillar heights and/or pedestal for larger hook paths
- Chain hoist with electric travel
- Slewing motion limit stops
- Locking arrangement for the jib
- Low-maintenance flat-cable festoon power supply
- Control travelling separately along the jib
- Radio control system.

## D-AS pillar-mounted slewing jibs

 **Operating range**

SWL [kg]	Outreach [m]									
	2	3	4	5	6	7	8	9	10	
80	Blue	Blue	Blue	Blue	Blue	Blue	Blue	Blue	Blue	Blue
125	Blue	Blue	Blue	Blue	Blue	Blue	Blue	Blue	Blue	Blue
250	Blue	Blue	Blue	Blue	Blue	Blue	Blue	Blue	Blue	Blue
500	Blue	Blue	Blue	Blue	Blue	Blue	Blue	Blue	Blue	Blue
1,000	Blue	Blue	Blue	Blue	Blue	Blue	Blue	Blue	Blue	Blue
1,600	Blue	Blue	Blue	Blue	Blue	Blue	Blue	Blue	Blue	Blue
2,000	Blue	Blue	Blue	Blue	Blue	Blue	Blue	Blue	Blue	Blue



The light-weight design and low-headroom jib make this pillar-mounted slewing jib crane suitable for universal applications in a load range up to 2,000 kg.

- Classification according to DIN 15018 H2B2
- Fitted with Demag chain hoist as standard
- I-beam profile jib
- Round pillar

### Options

- Anchor bolt set and template for fixing to foundations
- TOP anchor attachment
- KOMPAKT anchor attachment
- Anchor bolts
- Other pillar heights and/or pedestal for larger hook paths
- Chain hoist with electric travel
- Slewing motion limit stops
- Locking arrangement for the jib
- Low-maintenance flat-cable festoon power supply
- Control travelling separately along the jib
- Radio control system
- Equipment for outdoor operation.

## D-AW wall-mounted slewing jibs



D-AW wall-mounted slewing jibs are suitable for universal applications in the lower load range up to 2,000 kg. The low deadweight makes it easy to move the jib even under load. Thanks to their low headroom dimension, they can also be used wherever long hook paths are needed in spite of a low ceiling height.

- Classification according to DIN 15018 H2B2
- Fitted with Demag chain hoist as standard
- I-beam profile jib

		Operating range								
		Outreach [m]								
		2	3	4	5	6	7	8	9	10
SWL [kg]	80	■	■	■	■	■	■	■	■	■
	125	■	■	■	■	■	■	■	■	■
	250	■	■	■	■	■	■	■	■	■
	500	■	■	■	■	■	■	■	■	■
	1,000	■	■	■	■	■	■	■	■	■
	1,600	■	■	■	■	■	■	■	■	■
	2,000	■	■	■	■	■	■	■	■	■

### Options

- Wall bracket to accommodate the two bearing brackets of the jib
- Pillar bracket
- Chain hoist with electric travel
- Slewing motion limit stops
- Locking arrangement for the jib
- Low-maintenance flat-cable festoon power supply
- Control travelling separately along the jib
- Radio control system
- Equipment for outdoor operation.

## D-TS pillar-mounted slewing cranes

SWL [kg]	Operating range					
	Outreach [m]					
	2	3	4	5	6	7
80						
125						
250						
500						
1,000						
1,600						
2,000						
2,500						
3,200						
4,000						
5,000						



This slewing crane is the universal solution for a load range up to 5,000 kg. The low-headroom jib provides for particularly long hook paths for an unlimited slewing range. The jib can also be powered by an optional electric slewing drive for ease of operation.

- Classification according to DIN 15018 H2B2
- Fitted with Demag chain hoist as standard
- I-beam profile jib
- Round pillar

### Options

- Anchor bolt set and template for fixing to foundations
- TOP anchor attachment
- KOMPAKT anchor attachment
- Anchor bolts
- Other pillar heights and/or pedestal for larger hook paths
- Chain hoist with electric travel
- Slewing motion limit stops
- Locking arrangement for the jib
- Low-maintenance flat-cable festoon power supply
- Control travelling separately along the jib
- Radio control system
- Electric slewing drive
- Equipment for outdoor operation.

## D-MS pillar-mounted slewing cranes

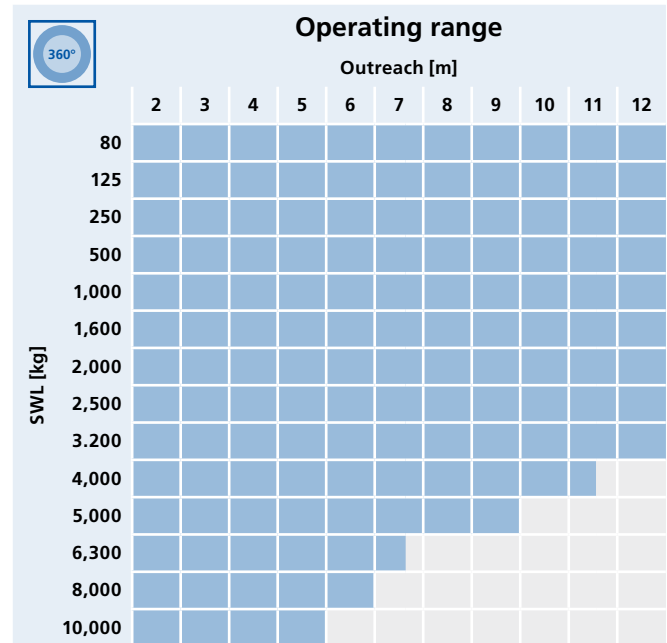

This pillar-mounted slewing crane features a high load capacity of up to 10,000 kg and a long outreach. The low-headroom jib provides for particularly long hook paths for an unlimited slewing range. It can also be powered by an optional electric slewing drive for ease of operation.

- Classification according to DIN 15018 H2B3
- Fitted with Demag chain hoist or Demag rope hoist as standard
- I-beam profile jib
- Round pillar

### Options

- Anchor bolt set and template for fixing to foundations
- TOP anchor attachment
- KOMPAKT anchor attachment
- Anchor bolts
- Other pillar heights and/or pedestal for larger hook paths
- Hoist with electric travel
- Slewing motion limit stops
- Locking arrangement for the jib
- Low-maintenance flat-cable festoon power supply
- Control travelling separately along the jib
- Radio control system
- Electric slewing drive
- Equipment for outdoor operation.

## D-GW wall-mounted slewing jibs

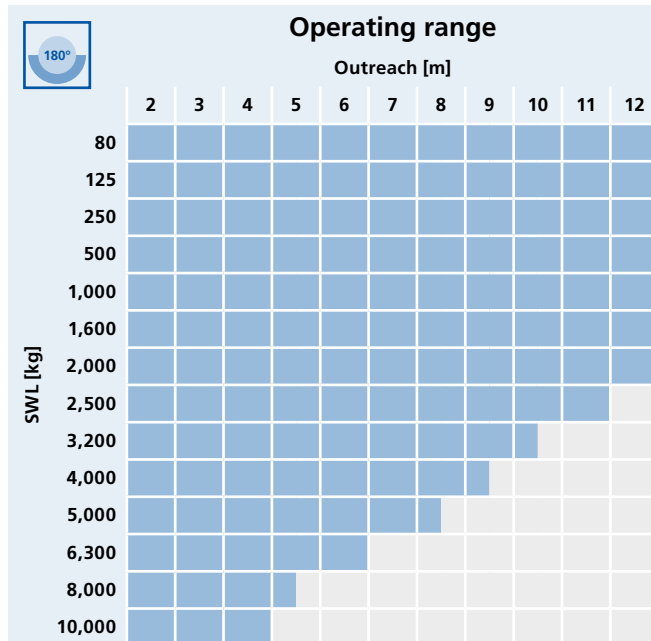

With its low-headroom jib and high load capacity, the D-GW wall-mounted slewing jib is suitable for a wide variety of applications. The crane is designed for use with Demag chain hoists or Demag rope hoists.

- Classification according to DIN 15018 H2B3
- Fitted with Demag chain hoist or Demag rope hoist as standard
- I-beam profile jib.

### Options

- Welding plates to accommodate the jib bearing brackets
- Wall bracket to accommodate the two bearing brackets of the jib
- Pillar bracket
- Hoist with electric travel
- Slewing motion limit stops
- Locking arrangement for the jib
- Low-maintenance flat-cable festoon power supply
- Electric slewing drive
- Equipment for outdoor operation.



# Solid connections

All wall and pillar connections for Demag slewing jib cranes offer maximum safety and ease of installation.

## Wall connections

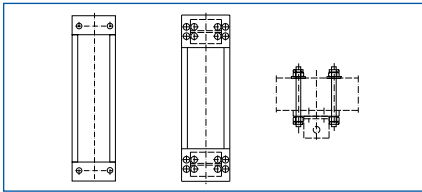

A **wall bracket** is used to attach cranes to a concrete wall, for example. The unit, which accommodates the two jib bearing brackets, is ready to be installed and is usually attached by means of suspension rods and secondary clamping plates.

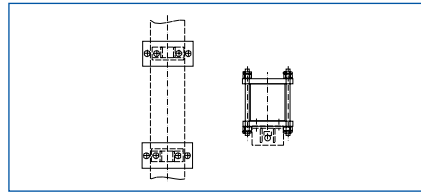

**Pillar brackets** can be used for simple attachment of wall-mounted slewing jib cranes to a wide range of pillar dimensions.

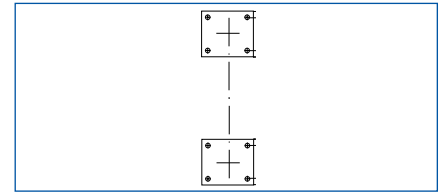

**Welding plates** accommodate the jib bearing brackets and are ready for installation for simple and reliable connection of cranes to steel structures.

## Pillar connections

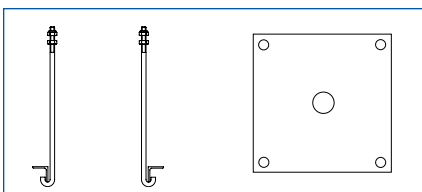

**Anchor bolts** are used to fix pillars to the foundations. A template is used for precise alignment of the anchor bolts with the mounting holes in the base of the crane pillar.

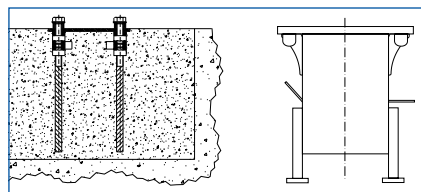

**TOP anchors** and **KOMPAKT anchors** are the optimum solution if a crane is used at several fixed locations. They are secured in the foundations flush with the floor, the base of the pillar is bolted into place without the need for any alignment or undergrouting. When the crane is dismantled, the floor is clear of any protruding edges or other obstacles.

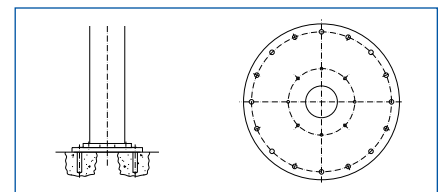

**Heavy-duty anchors** are used for securing pillar-mounted slewing cranes and jibs to existing concrete floors. Chemical anchor bolts for dynamic loads are used to fit an anchor plate to which the base of the crane pillar is then attached.

## Reliable operation in all weathers

Demag slewing jibs and cranes can also be operated outdoors. Additional protective components make the

cranes resistant to the effects of weather and guarantee a long service life and maximum availability.



❶ Various weather canopies are available for average local weather conditions, ranging from a canopy above the hoist parking position to complete roofs

❷ The crane can be securely locked in its parking position when subjected to strong wind forces and, if required, also fitted with a stronger drive to ensure safe and reliable operation in poor weather conditions

❸ Depending on the climate, the steel parts can also be provided with additional protection by means of a second coat of paint or a galvanised pillar and jib

❹ Control pendants can be protected against the weather by means of an enclosed housing. The use of a radio control system is recommended as the ideal alternative, however.

# Demag hoists for every application

Demag compact hoist units are available with a wide range of load capacities, hoist speeds and features.

They make a valuable contribution to the ergonomic layout of employees' workplaces and are characterised by the highest degree of reliability and safety.



## Demag DC-Com chain hoist

The universal chain hoist with two hoist speeds as standard for normal loads weighing up to 2,000 kg in normal applications.

- 4 m hook path as standard
- Height-adjustable control pendant
- Contactor control as standard.



## Demag DC-Pro/DCM-Pro chain hoists

They are particularly user-friendly and feature high standards of safety and reliability and optimum efficiency. Particularly long service life for loads weighing up to 5,000 kg.

- Comprehensive standard features: limit switches, elapsed operating time counter, contactor control, diagnosis interface
- Height-adjustable control pendant
- Also available with infinitely variable speed control for particularly smooth lifting, lowering and positioning motions.

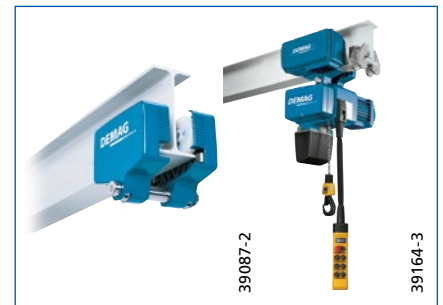

## U type trolleys for Demag chain hoists

U type trolleys enable Demag chain hoists to be moved by hand with ease. The low-wearing travel rollers provide for smooth operating characteristics and low travel resistance.

U type trolleys are designed for simple addition of an electric travel drive at a later date.



## Demag DR-Com low-headroom rope hoist

Can be used wherever load capacities up to 10,000 kg and long hook paths are required. Particularly suitable for precise positioning of loads thanks to variable cross-travel speed.

- 6 m hook path as standard
- Control via integrated CAN-bus control
- Overload protection.



Demag Cranes & Components GmbH  
 Modular Cranes Product Management  
 PO Box 67

58286 Wetter, Germany

**Fax enquiry: +49 (0) 2335 92-7676**

**Please send a quotation/the information to:**

Company \_\_\_\_\_

PO Box/street \_\_\_\_\_

Town/post code \_\_\_\_\_

Attention of \_\_\_\_\_

Phone/extension \_\_\_\_\_

Fax \_\_\_\_\_

Email \_\_\_\_\_

**Project engineering for a wall-mounted slewing jib**

Type \_\_\_\_\_

Weight of the load  $G_H$ : \_\_\_\_\_ kg

Length of the jib  $l$ : \_\_\_\_\_ m

Highest hook position  $H$ : \_\_\_\_\_ mm

Clear headroom  $h + \text{min. } 100 \text{ mm}$ : \_\_\_\_\_ mm

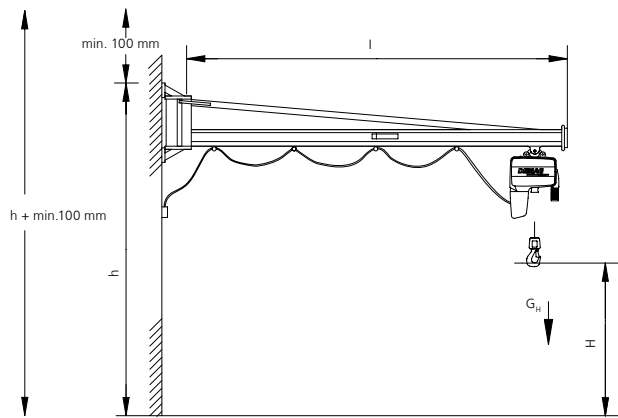

**Please state dimensions**

**Additional information**

- Attached: \_\_\_\_\_ Attachment material: \_\_\_\_\_  
 to steel pillar  provided by customer  
 to reinforced concrete pillar  please quote  
 to reinforced concrete wall

- Hoist: \_\_\_\_\_  
 Hoist speed: \_\_\_\_\_ m/min  
 Operating voltage: \_\_\_\_\_ V  
 Control voltage: \_\_\_\_\_ V  
 Slewing  manual  electric  
 Cross travel  manual  electric

**Project engineering for a pillar-mounted jib crane**

Type \_\_\_\_\_

Weight of the load  $G_H$ : \_\_\_\_\_ kg

Length of the jib  $l$ : \_\_\_\_\_ m

Highest hook position  $H$ : \_\_\_\_\_ mm

Clear headroom  $h + \text{min. } 100 \text{ mm}$ : \_\_\_\_\_ mm

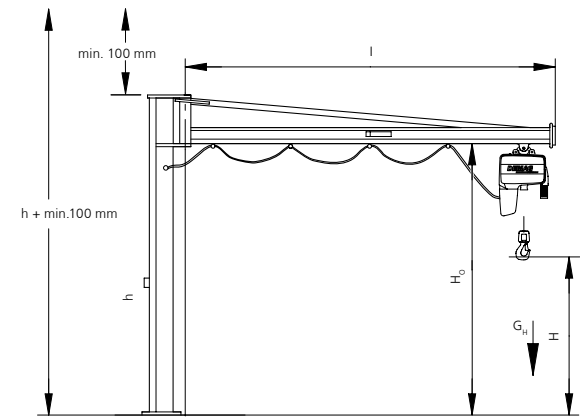

**Please state dimensions**

**Additional information**

- Foundation:  with anchor bolts  
 heavy-duty anchors in concrete floor.

- Hoist: \_\_\_\_\_  
 Hoist speed: \_\_\_\_\_ m/min  
 Operating voltage: \_\_\_\_\_ V  
 Control voltage: \_\_\_\_\_ V  
 Slewing  manual  electric  
 Cross travel  manual  electric

## Unique range of applications

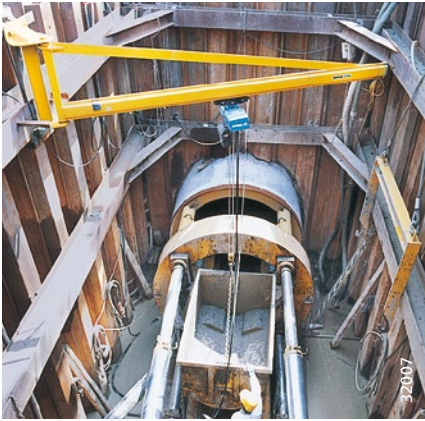

## Fast and simple planning with the jib crane Designer system

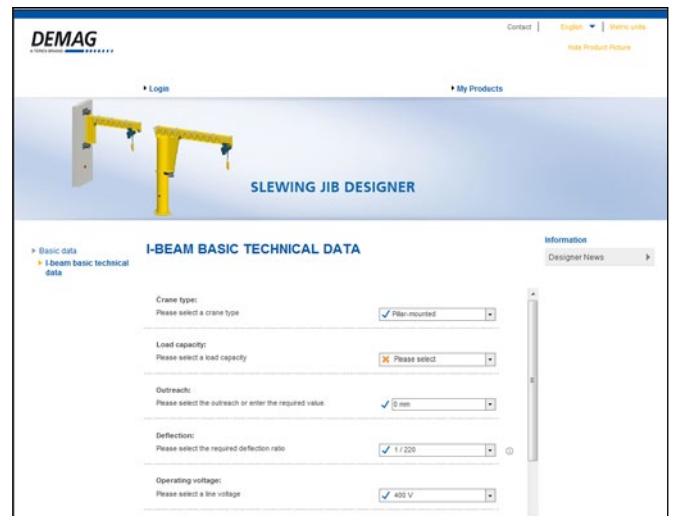
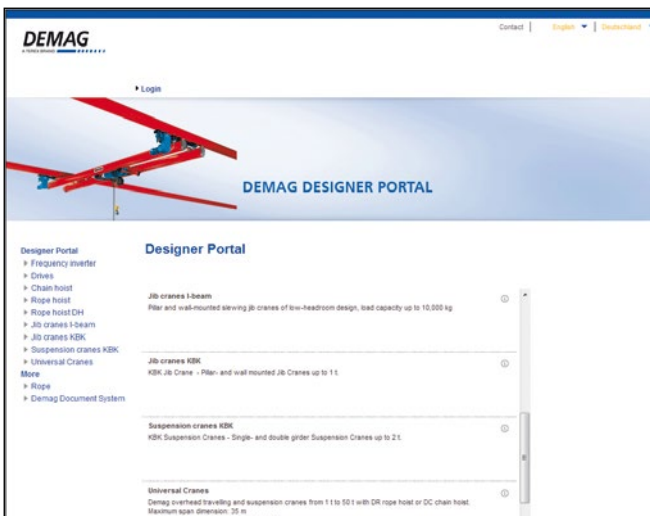

www.demag-designer.com is the address where all important facts and data on pillar and wall-mounted slewing cranes can be found. The two online tools for our slewing jib crane range provide you with project engineering support. You can download corresponding CAD files and integrate them into your design drawings. The intuitive user interface will assist you in finding the details you need quickly and easily. You can then send us your specific enquiry at the click of a mouse button.

### Always at your service

If you have any questions or need additional information, please use the fax page opposite or contact our sales engineers direct – find your nearest qualified contact at [www.demagcranes.com](http://www.demagcranes.com).