

Demag DC-Pro chain hoist Demag DCM-Pro Manulift

The new industry standard



Demag DC-Pro chain hoist: A new industrial standard – Made by Demag

All inclusive: fully featured instead of extras price list

Many features are already integrated into the Demag DC-Pro chain hoist as standard that have to be ordered

and bought as extras elsewhere.

The DC-Pro chain hoist is a fully featured, highly versatile chain hoist, which can be installed and put into service in a minimum of time.



That is “Standard – Made by Demag”, an investment with added value.

- 20 % longer service life and greater efficiency thanks to Demag **2m⁺**
- Improved safety and reliability thanks to 24 V contactor control and operating limit switches
- Fast and ergonomic height-adjustment of the control cable without the need for any wiring
- Flexibility as standard thanks to two sizes of suspension bracket
- Simple installation and commissioning thanks to plug connections – Plug & Lift und Plug & Drive
- Gearbox, brake and slipping clutch are maintenance-free for up to 10 years
- Smooth and fast load handling of loads with two hoist speeds
- Elapsed operating time counter and diagnostics interface provide information on the operating status – maintenance breaks can be planned
- The plug-fitted chain drive can be replaced quickly and easily

Tailored solutions

Certified

DC-Pro chain hoists are tested and approved by the relevant authorities and also meet the demanding requirements of the CSA specifications. Electromagnetic compatibility is rated according to EN 61000-6-2 to 4 for interference immunity in industrial environments and for interference emissions in commercial and industrial environments.



① **Gearbox** – maintenance-free for up to 10 years. With classification in FEM Group of Mechanisms Demag 2m+, the DC-Pro sets a new standard with a rated service life of 1900 hours at full load. In practical terms, this means the service life is extended by approx. 20 %. The helical gearing of all gearbox stages also reduces operating noise and provides for smooth operation.

② **Brake** – maintenance-free for up to 10 years (sizes DC 10–25 up to 5 years). Thanks to minimum wear, adjustment is not necessary; short and gentle run-on path. The brake enclosure features double encapsulation and is therefore impervious to poor weather and operating conditions.

③ **Slipping clutch** – maintenance-free for up to 10 years. Integrated behind the brake in the power drive, it provides reliable protection against extreme overload. Damaging permanent slipping is not possible thanks to integrated speed monitoring.

④ **Height adjustment of the control pendant** – The length of the control cable and, therefore, the suspension height of the control pendant can be infinitely varied for a hook path range of 2–5 m and 5–8 m. The length of control cable that is not required is accommodated under the service cover. The control cable is rated for electric travel applications in 3 axes.



⑤ **Control** – with 24 V contactor control, operating limit switches (upper/lower) and elapsed operating time counter as standard. A geared limit switch with four contacts for fast-to-slow and limit cut-off is used as the operating limit switch for sizes DC 16 and 25.

⑥ **Round steel chain** – a special Demag chain of high-strength, ageing-resistant material with high surface hardness. Galvanised and additionally surface-treated to protect against hostile environments.

⑦ **Suspension bracket** – DC-Pro chain hoists are suspended in pendulum fashion and make optimum use of the available height thanks to their small C headroom dimension. DC-Pro units are supplied with short and long suspension brackets as standard and can always be attached to the superstructure with the optimum connection.



⑧ **Housing** – robust and weight-saving die-cast aluminium housing of compact and modern industrial design. UV-resistant powder-coated finish is unsusceptible to knocks and scratches.

⑨ **Hoist motor** – robust and enduring high-performance motor with large safety reserves even at high ambient temperatures and in prolonged operation. 2 hoist speeds with F4 ratio as standard. (Insulation class F, 360 s/h and 60 % CDF)

⑩ **Chain drive** – The plug-in unit facilitates quick and easy replacement of the entire chain drive without having to remove the motor or gear parts. Downtimes can therefore be cut significantly. The chain drive consists of highly wear-resistant materials for a long service life.



⑪ **Chain collector box** – attached in pendulum fashion, made of tough, flexible and particularly impact-resistant plastic; capacity for up to 8 m hook path. Chain collector bag for chain lengths up to 40 m as well as special lengths up to 120 m can be supplied.

⑫ **Bottom block** – up to 1000 kg with single chain fall for improved ergonomic handling of the hook with fittings. Chain wear is simultaneously reduced, since no chain return arrangement is required. The new, compact and particularly ergonomic DC bottom block is used for 2/1 reeving arrangements. The cut-off springs required for the limit switches are integrated inside the bottom block and therefore save 60 mm of the valuable C dimension.

Increased performance, more speed



Increased performance, improved ergonomics, safety and reliability for greater productivity. The performance features of the new DC-Pro chain hoist provide for optimum efficiency.

Sensitive and fast

DC-Pro units can be integrated into your work and production processes flexibly and precisely. While the main lifting speed guarantees fast and effective operation at a minimum of 6 m/min, the creep lifting speed ensures that loads are handled gently and precisely.

2m⁺ – an even longer service life for greater efficiency.

In practical terms, Demag 2m⁺ means the service life is extended by approx. 20 % in comparison with the conventional 2m classification for chain hoists according to the FEM Group of Mechanisms. This results in significantly extended intervals for service work and general overhauls. This extra amount of lasting efficiency is only offered by the new Demag DC-Pro chain hoist.

Duration of service in full load hours

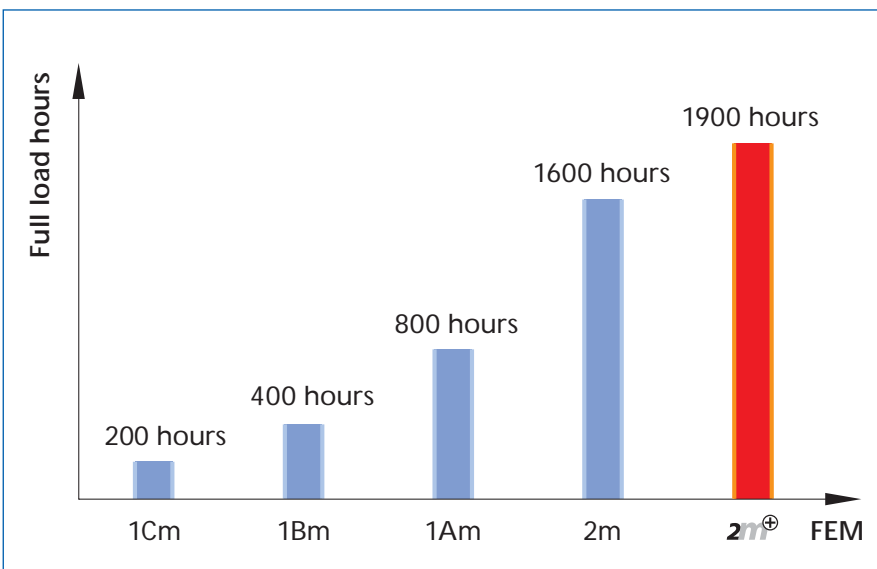

Improved safety and reliability

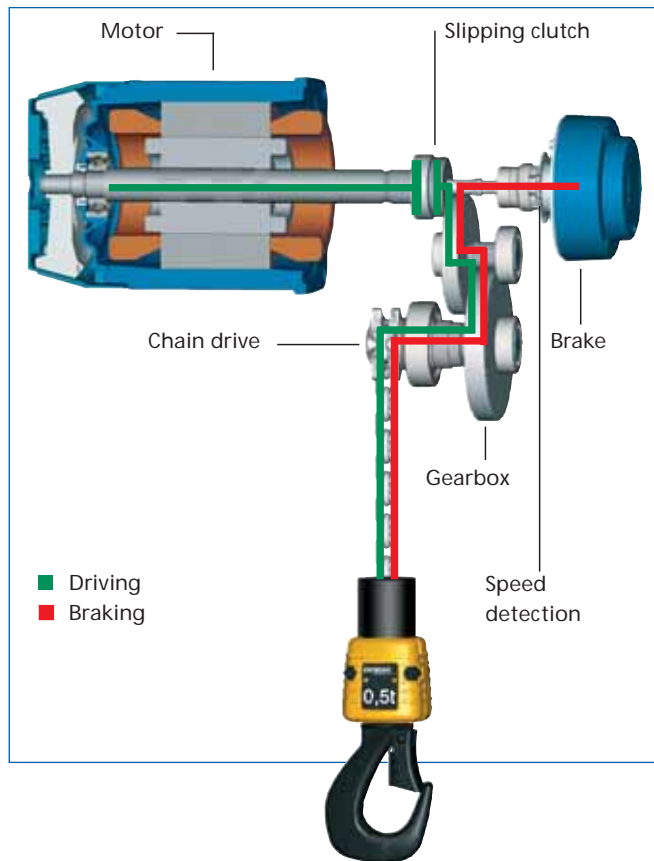

Thanks to the completely new safety concept developed for the Demag DC-Pro chain hoist, the gearbox, brake and coupling operate without the need for any maintenance for up to ten years (brake for sizes DC 10–25 up to 5 years). The brake-coupling system ensures that the load is held securely in any operating situation. The load cannot drop. This is achieved by arrangement of the brake direct in the power drive chain (red line). Thanks to minimum wear, the brake does not need to be adjusted. Operating safety is generally improved by the single-fall design up to a load capacity of 1000 kg.

The combination of electronic control system and integrated speed sensors continuously monitor the hoist motor, clutch and brake, thus ensuring lasting safety for the operator. The compact and light 24 V contactor control system also ensures that the system is subject to only minimum wear. The run-on path is both smooth and gentle.

The standard control system includes

- 24 V contactor control
- Operating limit switches (upper/lower) to switch the hoist motion off in the highest and lowest hook positions – sizes DC 16 and 25 with geared limit switch with four contacts for fast-to-slow and limit cut-off
- Elapsed operating time counter can be read from the outside
- Speed detection
- Infrared diagnostics interface

Control pendant: Always at the right operating height



Height adjustment of the control cable

The most favourable operating height for the control pendant can be easily adjusted on the Demag DC-Pro chain hoist. The adjusting mechanism integrated in the chain hoist housing enables the operator to change the suspension height of the control pendant easily and without the need for any tools or wiring. The control cable is designed for an adjustment range of 3 m. The length of control cable that is not required disappears beneath the DC-Pro service cover. This innovation has been implemented for the first time in a chain hoist.

The adjusting mechanism also contains the strain relief arrangement for the control cable and can resist extreme tensile loads. The same applies to the control cable, which is made of a proven and particularly tough material. At the same time, the control cable is flexible and therefore easy to handle.

Ergonomics: All in good hand

The DSC control pendant precisely interprets control commands in any situation. It facilitates fatigue-free operation for right and left-handed operators both with and without gloves. Furthermore, electrical interlocks prevent simultaneous initiation of motions in both directions.

Demag control pendants feature an optimised ergonomic sloping design for convenient operation. They are made of high-quality plastic which is highly resistant to impacts and are therefore extremely robust. With bending and impact protection as well as IP 65 enclosure against dust and moisture, DSC units are ideally suited for the demanding requirements of industrial applications. The DSC control pendant is specially developed for push-travel DC-Pro chain hoists and fitted with two-stage switching elements. The DSE 10-C control pendant is used for electric travel applications with E 11 / E 22 or E 34 drives.



The control pendant can be changed quickly and easily



Slide the protective sleeve upwards over the control cable



Fit the plug with its bayonet connector into the control pendant and turn until it locks



Push protective sleeve downwards

Commissioning: Plug & Lift and Plug & Drive

A great benefit offered by the new Demag DC-Pro chain hoist is simple commissioning. The pivoting suspension bracket and infinitely adjustable flange width of the U 11, U 22 and U 34 trolleys make the mechanical parts easy to install.

The plug-in connections beneath the service cover and the power plugs that are already included in the scope of delivery also make the electrical parts simple to connect. This enables the DC-Pro to be ready for operation in a minimum of time.



Integrated beneath the cover

You have rapid access to all important components for service and commissioning beneath the pivoting service cover

- Storage for 3 m of control cable
- Plug-in electrical connections for power cable, control cable, limit switches and trolley
- Strain relief for power supply and trolley supply cables
- Chain guide
- Chain lubrication

39044-2

Pivoting service cover

Maintenance: Fast and simple

All main drive components of the Demag DC-Pro chain hoist, such as the gearbox, brake and coupling, operate without the need for any maintenance for up to ten years (maintenance-free brake for up to 5 years for sizes 10–25). The outstanding Demag quality of all components provides for a long service life even under heavy use. The few necessary maintenance measures can be carried out quickly and easily thanks to the service-friendly design of the DC-Pro.

The chain drive of the DC-Pro, for example, is designed as a compact unit which is plugged into place and can be replaced in a minimum of time without the need to disassemble motor or gearbox parts. Long downtimes as a result of maintenance work are now a thing of the past.



39241-22

Chain drive

Diagnosis – wireless via display or via infrared

Service technicians can read the standard operating time counter or call up the relevant information on the operating status – from the outside via the display on the base of the chain hoist housing or by means of the diagnosis interface via infrared data transfer.

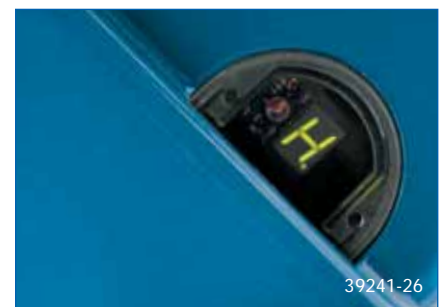

39241-26

Diagnosis interface

Demag DCM-Pro Manulift: Ergonomic single-handed load handling at the workplace

The DCM-Pro Manulift was developed for handling loads quickly and safely with only one hand. The new DCM-Pro is based on the lifting unit of the DC-Pro chain hoist and the DSM-C control unit which is connected to it by a helical cable. Thanks to the control unit which is rigidly connected to the load handling attachment for right and left-handed operation, the operator only needs one hand to operate the chain hoist and guide the load.

The quick-change coupling enables a wide variety of load handling attachments to be changed with ease. All Manulift load handling attachments are fitted with a connecting pin with a swivel lock, which snaps into the quick-change coupling. It can be easily disconnected by lifting the unlocking sleeve.

Manulift units can travel on Demag KBK profile sections and I-beams (see pages 16 – 23), which enables them to be flexibly integrated into work and production processes.



39143



39204-7



Load hook
250 kg



Slewing load hook
250 kg



Open hook
125 kg



Belt sling
125 kg

Versatile adaptability to any task

A variety of proven load handling attachments facilitate optimum and flexible adaptation of the chain hoist to meet your needs. They range from normal load hooks and various pantograph-type tongs to parallel gripper systems, e.g. for KLT containers used in the automotive industry. The DCM-Pro Manulift can be used with specially developed load handling attachments. The universal coupling pin is used to connect customer-designed attachments.

It is provided with an M12 internal thread for connecting special load handling attachments.

Manulift load handling attachments can also be connected to the DC-Pro chain hoist load hook by means of an adapter. The versatility and flexibility of the new Demag chain hoist provide for improved load handling efficiency at the workplace.

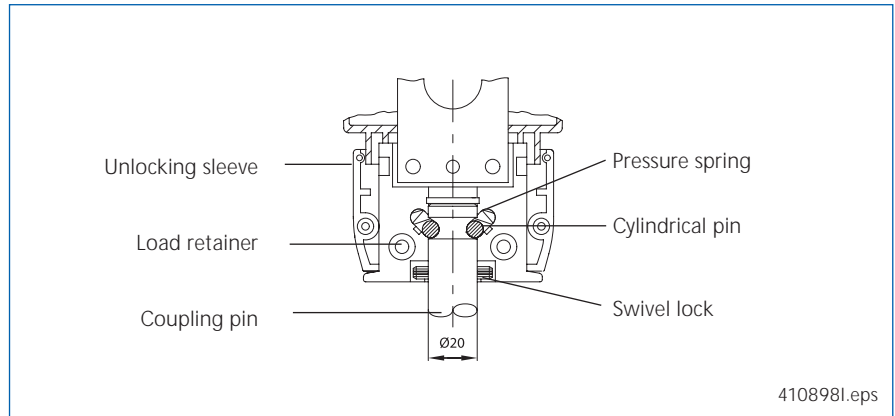

The quick-change coupling on the DSM-C control unit



PGS-parallel gripper
125 kg



Pantograph tongs for gripping square goods
125 kg



Pantograph tongs for gripping round goods
125 kg



Load hook adapter
up to 250 kg



Load hook adapter with connected PGS shaft gripper

PGS parallel gripper system: Firm hold on loads up to 125 kg

PGS box grippers

The narrow design and short opening path of the grippers make it possible to pick up and deposit goods safely and easily, even in restricted spaces, and to place them direct into cartons. The 100 mm wide gripping range makes it possible to transport both the actual goods as well as a packed unit using the same gripper.



PGS shaft grippers

Various shaft grippers are available which can be adapted to different shaft types and applications by changing the gripper jaws.

When fitted with a shaft support, they can be used to pick up shafts with various diameters or an unknown centre of gravity. This significantly improves the safety of handling tasks that, until now, have always involved a certain risk.

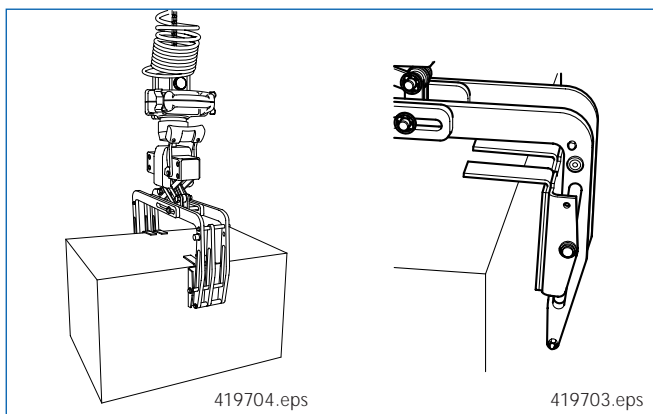

PGS container grippers

The various container grippers can be supplied for fixed or adjustable container widths. They are easily adjusted to the relevant container size by lifting and turning the locking pins, and by pushing the grippers together or pulling them apart until the stops are reached.

| Container type | Container size | |
|---|----------------|-----------|
| | 600 x 400 | 400 x 300 |
| Euro container | rigid | rigid |
| KLT (VDMA) | rigid | rigid |
| | adjustable | |
| Various containers such as PDB, ARCA, MF, SSI Schäfer, Eurotec, Utz KLT, Bito | rigid | rigid |
| | adjustable | |

Grippers for other container types on request

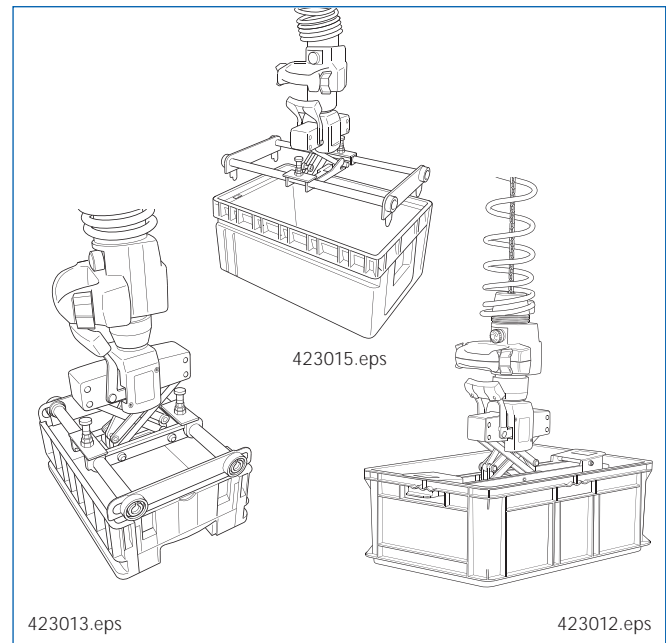

Grippers for various container types

Slewing jibs facilitate load handling at the workplace

Pillar- and wall-mounted slewing jibs with the DC-Pro chain hoist provide inexpensive support at the workplace and facilitate space-saving load handling in production, storage and shipping. When used direct on production

machinery, they help to cut setting-up and idle times. Wall- and pillar-mounted slewing jibs and pillar-mounted slewing cranes are suitable for virtually any application as standard.



Wall-mounted slewing jibs

These cranes, which take up no floor space, can be used wherever load-bearing concrete walls or pillars are available. The slewing range of up to 270° and the possibility to fit them to machinery and installations makes them ideal for a wide range of applications.



Pillar-mounted slewing jibs and cranes

The locations served by these free-standing cranes are utilised to the full thanks to their slewing range of up to $n \times 360^\circ$. They can be used for many applications. They can be erected indoors or outside and used for handling goods at loading ramps or for serving machinery. These cranes provide maximum hook paths even where only little headroom is available. The pillar has only a small footprint and is either anchored to the foundations using anchor rods or to an existing concrete floor using anchor bolts.

KBK slewing jibs feature struts and hollow profile section rails and offer a low deadweight for load capacities up to 1000 kg. Loads can be moved quite simply by hand.

The product range of the I-beam slewing jibs covers a load range up to 10000 kg as standard.

See brochure 208 756 44 for further information on pillar and wall-mounted slewing jibs and cranes.



39187-1

Efficient material flow with KBK track and crane installations

Interlinking production processes, serving machinery, moving materials – all handling and transport tasks have one thing in common: loads not only have to be lifted and lowered, horizontal motions are also required.

The KBK crane construction kit is the ideal horizontal transport system for the DC-Pro and DCM-Pro Manulift. KBK installations are used for both linear and area-serving load transport.



Suspension cranes

Single and double-girder suspension cranes are used for area-serving load handling. The low deadweight enables loads to be easily moved by hand. Travel drives are also available for precise positioning of larger loads.



Portal cranes

Portal cranes from the KBK system are not mounted on rails and can be easily moved. When fitted with the DC-Pro chain hoist, this makes them ideal and flexible lifting devices, above all for repair and assembly work.

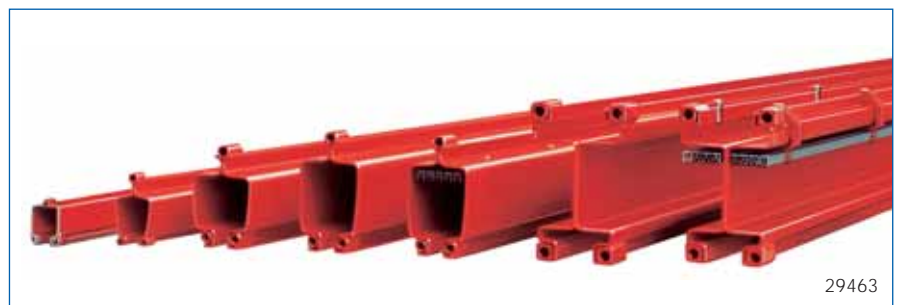

KBK sections are available in various sizes for different load capacities

Many components are available to create efficient overhead materials handling solutions to meet specific application requirements. The KBK crane construction kit is a suspension system which uses no valuable floor space and therefore leaves

production area free. It is completely modular in design, all connections are bolted or fitted. This enables installations to be modified or extended easily and cost-effectively. These are Demag system solutions for practical material flow requirements.



Suspension monorails

Suspension monorails are the preferred linear solution to connect pick-up and deposit positions. The many possible designs from simple, manually controlled straight sections to complex, semi or fully automated closed-circuit monorail systems enable a wide variety of applications to be implemented. Flexible routing by means of straight and curved sections, track switches and turntables facilitates cost-effective adaptation to the most diverse operating conditions.

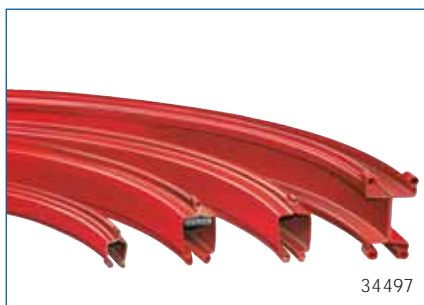

Sections in various profile sizes for curved tracks



KBK Aluline – aluminium profile sections

See brochure 208 385 44 for further information on track and crane systems from the KBK crane construction kit.

Push-travel trolleys for simple horizontal movement

U trolley

The new U trolley generation is available in two sizes for load capacities up to 1100 kg (U 11), 2200 kg (U 22) and 3400 kg (U 34). The flange width can be infinitely adjusted by means of two adjusting rings and covers the ranges from 58 mm to 200 mm, and 201 mm to 310 mm. This facilitates fast and simple installation.

The travel rollers, which are made of high-strength and wear-resistant Polyamide, provide for smooth operating characteristics and low travel resistance. Optional steel rollers can also be used for special ambient conditions, e.g. high temperatures. The universal design of the travel rollers enables them to be used for operation on straight and sloping profile sections.



39032-1



39087-2

The lateral steel guide rollers support their curve-negotiating properties down to the minimum radius of 1000 mm and minimise girder wear. A drop-stop arrangement is integrated into the side cheeks, which consist of aluminium die-castings with a powder-coated finish.

Push-travel U trolleys are designed for simple addition of the E electric travel drive at a later date.



39136-1

CF 5 click-fit trolley

Simply clicked onto the girder, curve-negotiating Click-fit trolleys are ready for operation with a load capacity of up to 550 kg.

The flange widths from 58 to 91 mm, the minimum curve radius of 800 mm and easy adaptability to standard section or parallel flange girders make them suitable for universal applications. The integrated drop-stop and lift-off protection provides for safe operation.

Plug & Drive with electric trolleys

EU trolley

The E 11, E 22 and E 34 electric travel drives were specially developed for operation with the new DC-Pro chain hoist. This significantly extends the range of applications of this state-of-the-art hoist.

The travel drives can be adapted to the U 11 – U 34 trolleys. Particularly short approach dimensions can be achieved when the units are mounted in a vertical arrangement. Fast retro-fitting and commissioning offer further benefits as no changes need to be made to the push-travel trolleys.



The drive is simply connected to the DC-Pro chain hoist using plug connectors and operated by means of the newly developed DSE 10-C control pendant. The control pendant for long and cross travel is simply fitted by means of a connector. The E 22 travel drive is used as standard for the KBK rail system with the new RF 125 friction wheel travel drive.

The E electric travel drive features a state-of-the-art, compact industrial design and offers outstanding travel characteristics. The control system integrated in the

travel unit provides for gentle starting and braking for low-sway load handling. A convenient load-sway damping system can be activated for the cross-travel motion. The speeds and acceleration and braking rates can also be modified by means of the DSE-10 C control pendant, if required. All electrical connections are of plug-in design.

The trolleys can also be fitted with an optional cross-type limit witch, either with fast-to-slow and limit switch cut-off or only with limit switch cut-off.



Clamp-fitted buffers to limit travel

KPA/KPT clamp-fitted buffers are the ideal solution to limit travel and are suitable for all DC-Pro trolleys. They can be fitted to sloping and parallel I-beam girders quickly and easily using screws. The travel range is shortened or extended by simply relocating the buffers.

They can be adapted to flange widths from 50 to 300 mm for universal applications.

They are suitable temperature ranges from -20°C to $+70^{\circ}\text{C}$ as well as for operation outdoors thanks to adequate resistance to ageing, ozone and weather conditions. Furthermore, they offer good resistance to acids and lyes. The tightening torque details are cast into the buffer to ease assembly.



39716

Magnets as versatile load handling attachments

DPMN permanent magnets

They offer low operating costs, constant availability and versatility and are suitable for operation both inside manufacturing facilities and outdoors. They function independently of a power supply and are safe, easy and reliable to operate.

When switched to "magnetise", a magnetic field is created between two field poles; no magnetism remains when switched to "demagnetise". The outer surface of the magnet armature is always neutral and offers maximum protection against external influences.



DBM 34/68 battery magnets

The compact unit consists of an electromagnet, battery and control unit with an integrated charging set. Battery magnets operate independently of a mains power supply and are used in stationary and travelling applications. They offer safe, reliable and easy operation in stores or production areas. The charging operation is controlled automatically and the charge level is indicated by the battery monitoring display.



R 26 round magnets

These single magnets offer enormous strength. The solid housing is made of highly permeable steel and the coil consists of fully encapsulated enamelled copper wire. They are fitted with integrated rectifiers and switches as standard.

Service – ready to help around the clock

All over the world

We offer you service around the clock with our world-wide network of Demag expert service teams and Demag partners. This ensures the highest availability and safety in your installation.

Rapid and reliable spare part supply

Any spare parts needed can be shipped 24 hours a day, 7 days a week.

Service systems: Demag IDAPSY

We have developed a new integrated service system for the new Demag DC-Pro chain hoist: Demag IDAPSY. IDAPSY stands for **I**nspection **D**iagnosis **A**pplication **S**ystem.

And these are your benefits:

■ Transparency

By recording utilisation of the installation, Demag IDAPSY facilitates predictive and plannable service. This enables a high level of availability to be ensured.

■ Analysis

Recorded data provides an excellent basis for analysis. The load spectrum recorder can be read out or error messages can be called up for maintenance or repair purposes, for example.

■ Efficiency

Maintenance work carried out in good time to ensure your installation is in optimum condition increases overall efficiency.

Demag IDAPSY enables service work to be carried out more quickly. This means that your hoist is ready for operation again even more quickly if service work has to be carried out.

Your individual service package

Demag Service and our Demag partners offer a comprehensive portfolio of services to ensure the lasting availability of your installation throughout its entire lifecycle:

- Recurring inspections according to relevant accident prevention regulations
- Inspection and maintenance
- Fault elimination both with and without on-call standby
- Service training for operators and maintenance engineers



39464-2



39040

39040

Selection criteria

The size of the hoist is determined by the load spectrum, average operating time per working day, SWL and reeving.

1. What are the operating conditions?
2. What is the specified safe working load?
3. To what height must the load be lifted?
4. What is the required lifting speed?
5. Do the loads need to be lifted and lowered with high precision?
6. Is horizontal load travel necessary?
7. How is the hoist to be controlled?

The load spectrum

(in most cases estimated) can be evaluated in accordance with the following definitions:

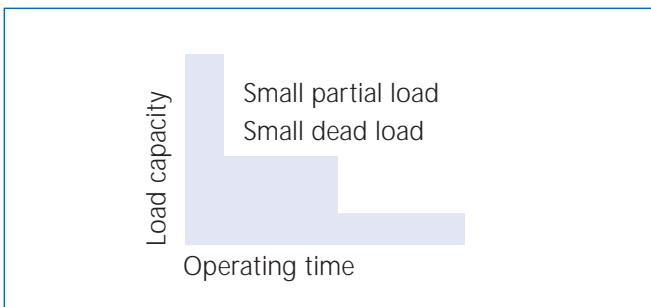

1 Light

Hoist units which are usually subject to very small loads and only in exceptional cases to maximum loads.

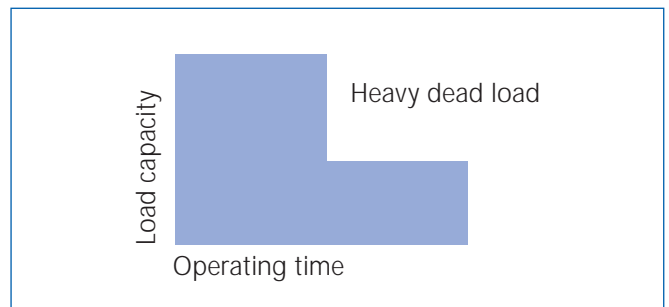

3 Heavy

Hoist units which are usually subject to medium loads but frequently to maximum loads.

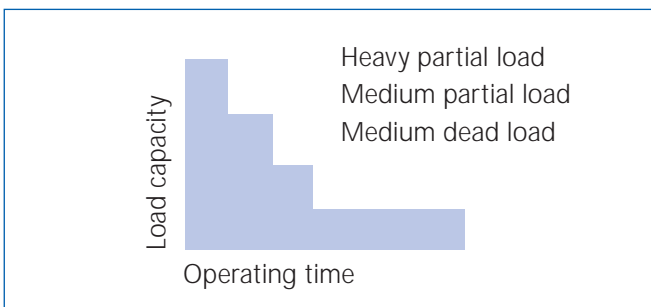

2 Medium

Hoist units which are usually subject to small loads but rather often to maximum loads.

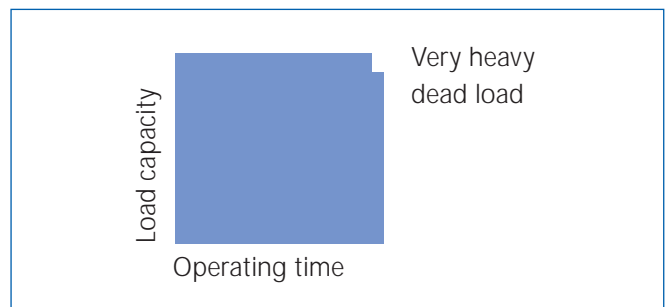

4 Very heavy

Hoist units which are usually subject to maximum and almost maximum loads.

The group is determined by the load spectrum and operating time.

| Load spectrum | | | Average operating time per day in hours | | | |
|----------------------------|------------|--|---|-------|------|---------|
| L1 | Light | | 2-4 | 4-8 | 8-16 | over 16 |
| L2 | Medium | | 1-2 | 2-4 | 4-8 | 8-16 |
| L3 | Heavy | | 0.5-1 | 1-2 | 2-4 | 4-8 |
| L4 | Very heavy | | 0.25-0.5 | 0.5-1 | 1-2 | 2-4 |
| Group of mechanisms to FEM | | | 1Am | 2m+ | 3m | 4m |

| Reeving | | Range | | Size | |
|----------------------|------|---------------------|--|------|------|
| SWL in kg | | | | | |
| 1/1 | 2/1 | | | | |
| Demag DC chain hoist | | | | | |
| 80 | | DC-Pro 1 / DC-Pro 2 | | | 80 |
| 100 | | DC-Pro 1 / DC-Pro 2 | | | 100 |
| 125 | | DC-Pro 1 / DC-Pro 2 | | | 125 |
| 160 | | DC-Pro 2 | | | 160 |
| 160 | | DC-Pro 5 | | | 160 |
| 200 | | DC-Pro 2 | | 200 | 200 |
| 200 | | DC-Pro 5 | | | 200 |
| 250 | | DC-Pro 2 | | 250 | 250 |
| 252 | | DC-Pro 5 | | | 250 |
| 315 | | DC-Pro 5 | | | 315 |
| 315 | | DC-Pro 10 | | | 315 |
| 400 | | DC-Pro 5 | | 400 | 400 |
| 400 | | DC-Pro 10 | | | 400 |
| 500 | | DC-Pro 5 | | 500 | 500 |
| 500 | | DC-Pro 10 | | | 500 |
| 630 | | DC-Pro 10 | | | 630 |
| 800 | | DC-Pro 10 | | 800 | 800 |
| 1000 | | DC-Pro 10 | | 1000 | 1000 |
| 1250 | | DC-Pro 10 | | 1250 | 1250 |
| 1250 | | DC-Pro 16 | | | 1250 |
| 1600 | 1250 | DC-Pro 10 | | 1600 | 1250 |
| 1600 | | DC-Pro 16 | | | 1600 |
| 2000 | 1600 | DC-Pro 10 | | 2000 | 1600 |
| 2000 | | DC-Pro 25 | | 2000 | 2000 |
| 2500 | 2000 | DC-Pro 10 | | 2500 | 2000 |
| 2500 | | DC-Pro 25 | | 2500 | 2500 |
| | 2500 | DC-Pro 10 | | 2500 | |
| | 3200 | DC-Pro 16 | | 3200 | |
| | 4000 | DC-Pro 25 | | 4000 | |
| | 5000 | DC-Pro 25 | | 5000 | |

Example: →
 SWL 250 kg
 Load spectrum „medium“ from table
 Lifting speed 8 m/min;
 1/1 reeving
 average hook path 4 m;
 Number of cycles/hour 20
 Working time/day 8 hours

The average operating time per working day is estimated or calculated as follows:

$$\begin{aligned} \text{Operating time/day} &= \frac{2 \cdot \text{average hook path} \cdot \text{no. of cycles/h} \cdot \text{working time/day}}{60 \cdot \text{speed hoist}} \\ &= \frac{2 \cdot 4 \cdot 20 \cdot 8}{60 \cdot 8} = 2.66 \text{ hours} \end{aligned}$$

For the medium load spectrum and an average daily operating time of 2.66 hours, the table shows group 2m+. For a load capacity of 250 kg, the diagram shows size DC-Pro 2-250.

Technical data

Model code

| | | | | | | | | | | |
|----|-------------------|------|------|-----|----|--------|-------------|----|------|-------------------------------|
| EU | DC-Pro | 10 - | 2000 | 2/1 | H5 | V6/1,5 | 380 - 415 / | 50 | 24/6 | 100 |
| | | | | | | | | | | Flange width [mm] or I beam |
| | | | | | | | | | | Travel speed [m/min] |
| | | | | | | | | | | Frequency [Hz] |
| | | | | | | | | | | Voltage range chain hoist [V] |
| | | | | | | | | | | Hoist speed [m/min] |
| | | | | | | | | | | Hook path [m] |
| | | | | | | | | | | Reeving |
| | | | | | | | | | | Load capacity [kg] |
| | | | | | | | | | | Size |
| | | | | | | | | | | DC Demag chain hoist |
| | | | | | | | | | | Trolley type |
| CF | Click-fit trolley | | | | | | | | | E Electric travel drive |
| U | Travelling hoist | | | | | | | | | D Articulated trolley |
| R | Push travel | | | | | | | | | |

Demag DCM-Pro Manulift selection table

| Load capacity [kg] | Manulift Typ | Hoist speed | | Motor size | Hook path [m] | Group of mechanisms FEM | Reeving | Max. weight for 2,8 and 4,3 hook path [kg] | | |
|-----------------------|-----------------|------------------|------------------|--------------|-------------------|----------------------------|---------|---|-------------------|---------|
| | | [m/min at 50 Hz] | [m/min at 60 Hz] | | | | | | | |
| 80 | DCM-Pro 1 - ... | 8/2 | 9.6/2.4 | ZNK 71 B 8/2 | 2.8 and 4.3 | 4m | 1/1 | 22 / 23 | | |
| | DCM-Pro 2 - ... | 16/4 | 19.2/4.8 | | | | | | | |
| 125 | DCM-Pro 1 - ... | 8/2 | 9.6/2.4 | | | | | | | |
| | DCM-Pro 2 - ... | 16/4 | 19.2/4.8 | | | | | | | |
| 250 | DCM-Pro 2 - ... | 8/2 | 9.6/2.4 | | ZNK 80 B 8/2 | | | | 2m+ ¹⁾ | |
| | DCM-Pro 5 - ... | 16/4 | 19.2/4.8 | | | | | | 4m | 28 / 29 |

1) 2m+ corresponds to 1900 hours at full load

Demag DCM-Pro Manulift dimension table

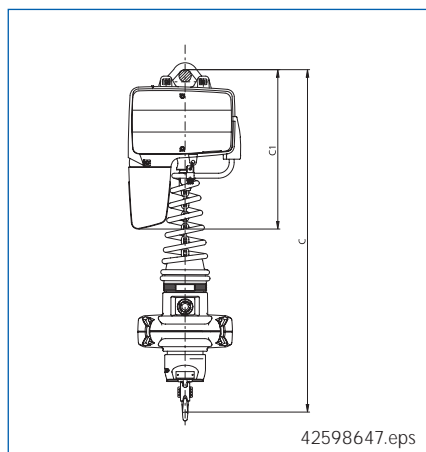

| Size | Short suspension bracket | | | Long suspension bracket | | |
|-----------|--------------------------|-------|---------------------------------|-------------------------|-------|---------------------------------|
| | C | | C1 Chain collector box H5 | C | | C1 Chain collector box H5 |
| | for hook path | | | for hook path | | |
| | 2.8 m | 4.3 m | | 2.8 m | 4.3 m | |
| DCM-Pro 1 | 635 | 705 | 335 | 673 | 743 | 373 |
| DCM-Pro 2 | 635 | 705 | 335 | 673 | 743 | 373 |
| DCM-Pro 5 | 680 | 750 | 395 | 718 | 788 | 435 |

DC-Pro chain hoist selection table

| SWL [kg] | Chain hoist Typ | Hoist speed | | Motor size | Hook path ²⁾ [m] | Group of mechanisms FEM | Reeving | Max. weight at H5/H8 respect. H4 [kg] | | | |
|-------------|--------------------|------------------|------------------|---------------|--------------------------------|----------------------------|-------------------|--|--------------|----|---------|
| | | [m/min at 50 Hz] | [m/min at 60 Hz] | | | | | | | | |
| 80 | DC-Pro 1 -... | 8/2 | 9.6/2.4 | ZNK 71 B 8/2 | 5 and 8 | 4m | 1/1 | 22 / 24 | | | |
| | DC-Pro 2 -... | 16/4 | 19.2/4.8 | | | | | | | | |
| 100 | DC-Pro 1 -... | 8/2 | 9.6/2.4 | | | | | | | | |
| | DC-Pro 2 -... | 16/4 | 19.2/4.8 | | | | | | | | |
| 125 | DC-Pro 1 -... | 8/2 | 9.6/2.4 | | | | | | | | |
| | DC-Pro 2 -... | 16/4 | 19.2/4.8 | | | | | | | | |
| 160 | DC-Pro 2 -... | 8/2 | 9.6/2.4 | | | | | | ZNK 80 B 8/2 | | |
| | DC-Pro 5 -... | 16/4 | 19.2/4.8 | | | | | | | | |
| 200 | DC-Pro 2 -... | 8/2 | 9.6/2.4 | | | | | | ZNK 71 B 8/2 | 3m | 22 / 24 |
| | DC-Pro 5 -... | 16/4 | 19.2/4.8 | | | | | | ZNK 80 B 8/2 | 4m | 28 / 30 |
| 250 | DC-Pro 2 -... | 8/2 | 9.6/2.4 | ZNK 71 B 8/2 | 2m+ ¹⁾ | 22 / 24 | | | | | |
| | DC-Pro 5 -... | 16/4 | 19.2/4.8 | ZNK 80 A 8/2 | 4m | 28 / 30 | | | | | |
| 315 | DC-Pro 5 -... | 8/2 | 9.6/2.4 | ZNK 80 A 8/2 | 4m | 28 / 30 | | | | | |
| | DC-Pro 10 -... | 12/3 | 14.4/3.6 | ZNK 100 A 8/2 | 4m | 48 / 52 | | | | | |
| 400 | DC-Pro 5 -... | 8/2 | 9.6/2.4 | ZNK 80 A 8/2 | 3m | 28 / 30 | | | | | |
| | DC-Pro 10 -... | 12/3 | 14.4/3.6 | ZNK 100 A 8/2 | 4m | 48 / 52 | | | | | |
| 500 | DC-Pro 5 -... | 8/2 | 9.6/2.4 | ZNK 80 A 8/2 | 2m+ ¹⁾ | 28 / 30 | | | | | |
| | DC-Pro 10 -... | 12/3 | 14.4/3.6 | ZNK 100 A 8/2 | 4m | 48 / 52 | | | | | |
| 630 | DC-Pro 10 -... | 6/1.5 | 7.2/1.8 | ZNK 100 A 8/2 | 4m | 48 / 52 | | | | | |
| | | 12/3 | 14.4/3.6 | ZNK 100 B 8/2 | | 56 / 60 | | | | | |
| 800 | DC-Pro 10 -... | 6/1.5 | 7.2/1.8 | ZNK 100 A 8/2 | 3m | 48 / 52 | | | | | |
| | | 12/3 | 14.4/3.6 | ZNK 100 B 8/2 | | 56 / 60 | | | | | |
| 1000 | DC-Pro 10 -... | 6/1.5 | 7.2/1.8 | ZNK 100 A 8/2 | 2m+ ¹⁾ | 48 / 52 | | | | | |
| | | 12/3 | 14.4/3.6 | ZNK 100 B 8/2 | | 56 / 60 | | | | | |
| 1250 | DC-Pro 10 -... | 6/1.5 | 7.2/1.8 | ZNK 100 B 8/2 | 5 and 8 | 4m | 2/1 | 65 / 73 | | | |
| | | 8/2 | 9.6/2.4 | | 4 | 1Am | 1/1 | 56 / 60 | | | |
| 1600 | DC-Pro 16 -... | 12/3 | 14.4/3.6 | ZNK 100 C 8/2 | 4 | 3m | 1/1 | 111 | | | |
| | | 6/1.5 | 7.2/1.8 | ZNK 100 B 8/2 | 5 and 8 | 3m | 2/1 | 65 / 73 | | | |
| | | | 8/2 | 9.6/2.4 | ZNK 100 B 8/2 | 4 | 2m+ ¹⁾ | 1/1 | 103 | | |
| 2000 | DC-Pro 16 -... | 12/3 | 14.4/3.6 | ZNK 100 C 8/2 | 4 | 2m+ ¹⁾ | 1/1 | 111 | | | |
| | | 6/1.5 | 7.2/1.8 | ZNK 100 B 8/2 | 5 and 8 | 2m+ ¹⁾ | 2/1 | 65 / 73 | | | |
| 2500 | DC-Pro 25 -... | 8/2 | 9.6/2.4 | ZNK 100 C 8/2 | 4 | 1Am | 1/1 | 113 | | | |
| | | 4/1 | 4.8/1.2 | ZNK 100 B 8/2 | 5 and 8 | 1Am | 2/1 | 65 / 73 | | | |
| 3200 | DC-Pro 25 -... | 8/2 | 9.6/2.4 | ZNK 100 C 8/2 | 4 | 2m+ ¹⁾ | 2/1 | 113 | | | |
| | | 4/1 | 4.8/1.2 | ZNK 100 B 8/2 | 4 | 2m+ ¹⁾ | 2/1 | 110 | | | |
| 4000 | DC-Pro 25 -... | 4/1 | 4.8/1.2 | | 4 | 2m+ ¹⁾ | 2/1 | 125 | | | |
| 1Am | | | | | | | | | | | |

1) 2m+ corresponds to 1900 hours at full load 2) Longer hook paths possible, please enquire

Demag DC-Pro chain hoist dimension tables

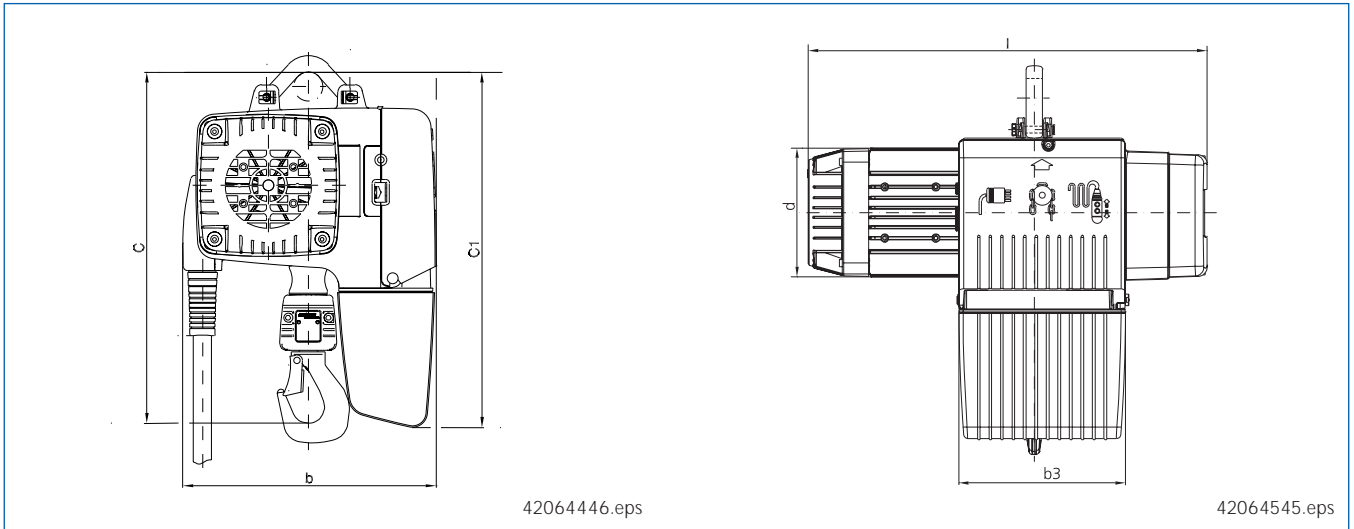

DC-Pro 1–10, up to 1000 kg 1/1 reeving

| Size | Motor | Suspension bracket | | | | | | b | l | b3 | d |
|-----------|---------------|--------------------|------|--------------------------|------|-----|-----|-----|-----|-----|-----|
| | | short | long | Chain collector box size | | C | | | | | |
| | | | | short | long | | C 1 | | | | |
| | | | | H5 | H8 | | | | | | |
| DC-Pro 1 | ZNK 71 B 8/2 | 326 | 364 | 335 | 365 | 373 | 403 | 268 | 422 | 183 | 124 |
| DC-Pro 2 | | | | | | | | | | | |
| DC-Pro 5 | ZNK 80 B 8/2 | 378 | 316 | 395 | 425 | 435 | 465 | 280 | 468 | 195 | 151 |
| DC-Pro 10 | ZNK 100 A 8/2 | 472 | 505 | 493 | 582 | 526 | 615 | 349 | 528 | 227 | 187 |
| DC-Pro 10 | ZNK 100 B 8/2 | 472 | 505 | 582 | 582 | 615 | 615 | 349 | 578 | 227 | 187 |

DC-Pro 10, 1250 to 2500 kg 2/1 reeving

| Size | Motor | Suspension bracket | | | | | | b | b3 | l | d | | |
|-----------|---------------|--------------------|------|--------------------------|------|-----|-----|-----|-----|-----|-----|-----|-----|
| | | short | long | Chain collector box size | | C | | | | | | | |
| | | | | short | long | | C 1 | | | | | | |
| | | | | H5 | H8 | | | | | | | H5 | H8 |
| DC-Pro 10 | ZNK 100 B 8/2 | 541 | 574 | 582 | 582 | 615 | 615 | 349 | 409 | 227 | 330 | 578 | 187 |

Demag DC-Pro chain hoist dimension tables

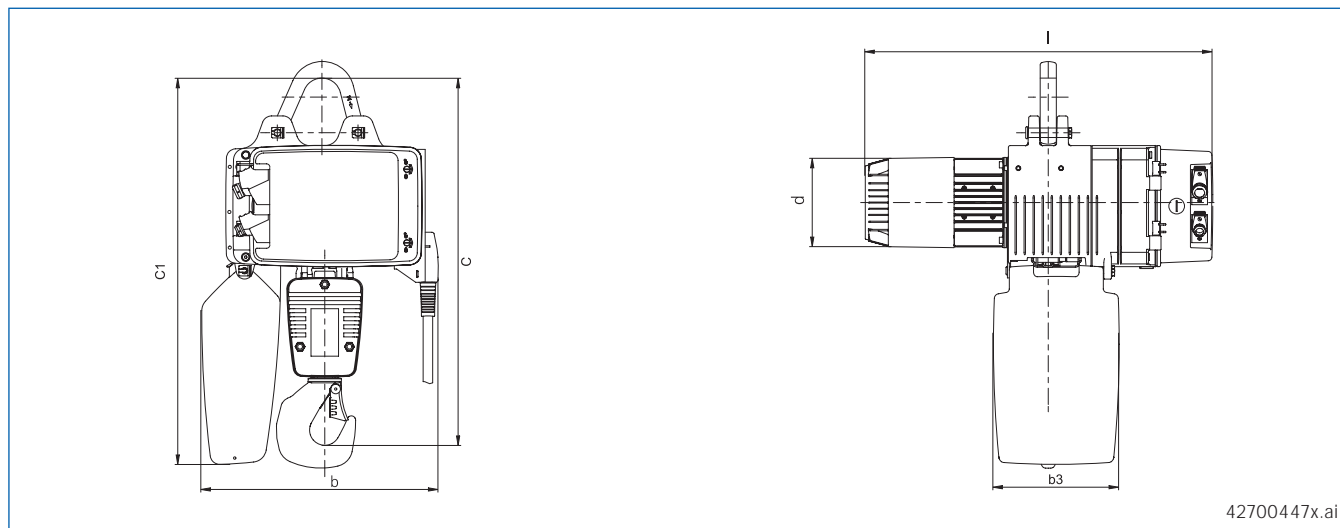

DC-Pro 16–25, 1250 to 2500 kg Reeving 1/1

| Size | Motor | C | Chain collector box size | | | | | | l | Chain collector box size | | d |
|-----------|---------------|-----|--------------------------|-----------|--------|-----------|--------|--------|-----|--------------------------|--------|-----|
| | | | Size 1 | Hook path | Size 2 | Hook path | Size 1 | Size 2 | | Size 1 | Size 2 | |
| | | | C 1 | | | | b | | | b3 | | |
| DC-Pro 16 | ZNK 100 B 8/2 | 640 | 813 | H14 | 893 | H30 | 490 | 501 | 679 | 265 | 325 | 187 |
| DC-Pro 25 | ZNK 100 C 8/2 | 640 | 813 | H10 | 893 | H20 | 490 | 501 | 732 | 265 | 325 | 187 |

DC-Pro 16–25, 2500 to 5000 kg Reeving 2/1

| Size | Motor | C | Chain collector box size | | | | | | l | Chain collector box size | | d |
|-----------|---------------|-----|--------------------------|-----------|--------|-----------|--------|--------|-----|--------------------------|-----|-----|
| | | | Size 1 | Hook path | Size 2 | Hook path | Size 1 | Size 2 | | H5 | H8 | |
| | | | C 1 | | | | b | | | b3 | | |
| DC-Pro 16 | ZNK 100 B 8/2 | 735 | 813 | H7 | 893 | H15 | 490 | 501 | 679 | 265 | 325 | 187 |
| | ZNK 100 C 8/2 | | | | | | | | 732 | | | |
| DC-Pro 25 | ZNK 100 C 8/2 | 770 | 813 | H5 | 893 | H10 | 490 | 501 | 732 | 265 | 325 | 187 |

DC-Pro chain hoist with CF 5 trolley dimension table

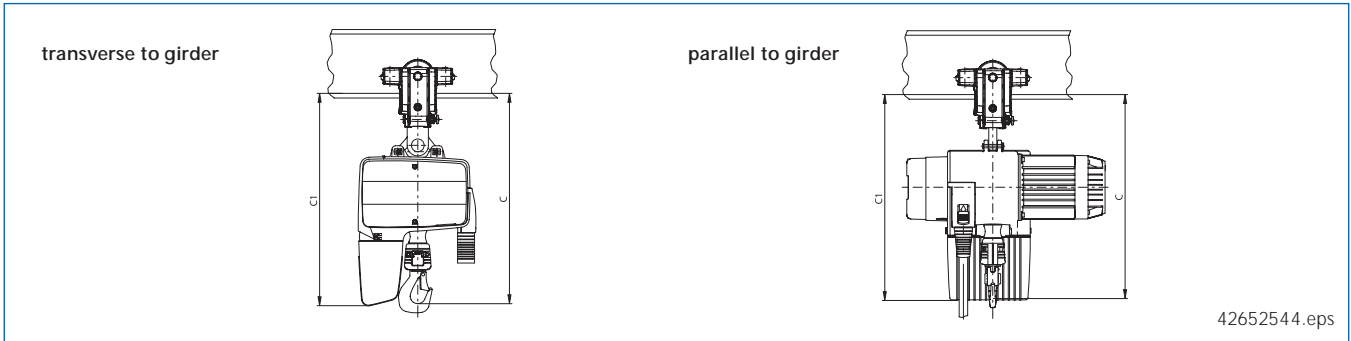

| Size | transverse to girder | | | parallel to girder | | |
|----------|----------------------|---------------------|-----|--------------------|---------------------|-----|
| | C | C1 | | C | C1 | |
| | | Chain collector box | | | Chain collector box | |
| | | H5 | H8 | | H5 | H8 |
| DC-Pro 1 | 385 | 415 | 445 | 380 | 410 | 440 |
| DC-Pro 2 | 385 | 415 | 445 | 380 | 410 | 440 |
| DC-Pro 5 | 430 | 477 | 507 | 425 | 472 | 502 |

Dimension table for DC-Pro 1 – 10 chain hoists with U 11, U 22 or U 34 trolleys

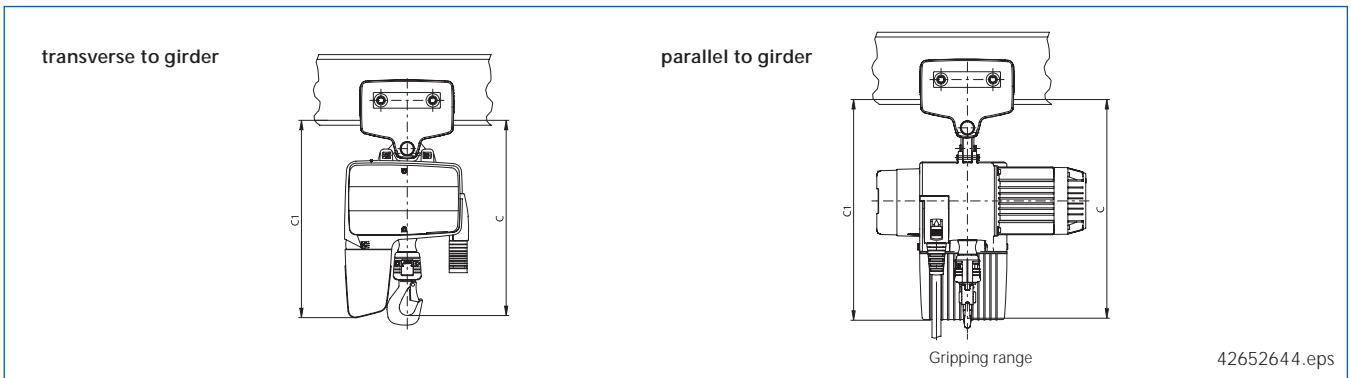

| Size | Reeving | Trolley | transverse to girder | | | parallel to girder | | |
|-----------|---------|-------------|----------------------|---------------------|-----|--------------------|---------------------|-----|
| | | | C | C1 | | C | C1 | |
| | | | | Chain collector box | | | Chain collector box | |
| | | | H5 | H8 | | H5 | H8 | |
| DC-Pro 1 | 1/1 | U 11 | 378 | 390 | 420 | 416 | 415 | 445 |
| DC-Pro 2 | 1/1 | U 11 | 378 | 390 | 420 | 416 | 415 | 445 |
| DC-Pro 5 | 1/1 | U 11 | 430 | 452 | 482 | 468 | 477 | 507 |
| DC-Pro 10 | 1/1 | U 11 | 524 | 578 | 667 | 557 | 602 | 691 |
| | 1/1 | U 22 | 536 | 590 | 679 | 569 | 614 | 703 |
| | 2/1 | U 22 / U 34 | 605 | 679 | 779 | 638 | 703 | 803 |

For further information, see U 11/U 22/U 34 technical data 203 570 44.

Dimension table for DC-Pro 16 and 25 chain hoists with U 22, U 34, RU 56 trolleys

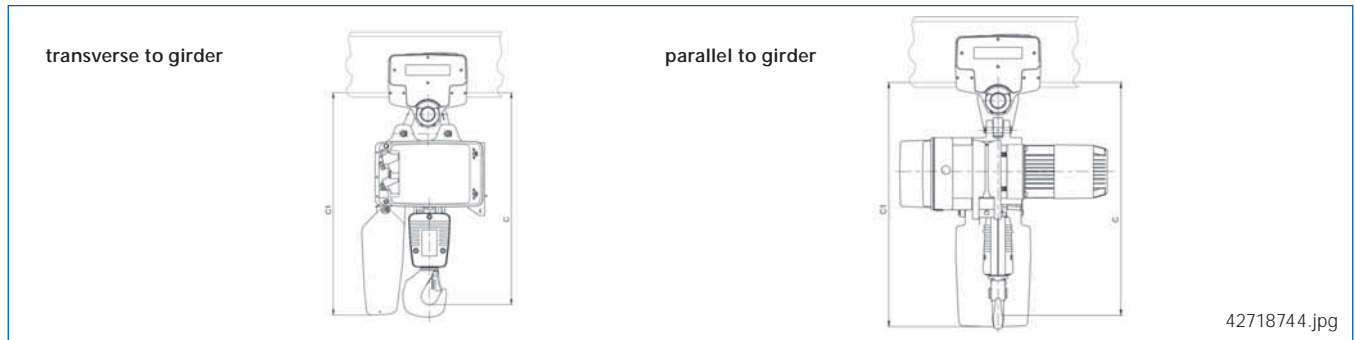

| Size | Reeving | Trolley | transverse to girder | | | parallel to girder | | |
|-----------|---------|---------|----------------------|---------------------|-------|--------------------|---------------------|------|
| | | | C | C1 | | C | C1 | |
| | | | | Chain collector box | | | Chain collector box | |
| | | | Gr. 1 | Gr. 2 | Gr. 1 | Gr. 2 | | |
| DC-Pro 16 | 1/1 | U 22 | 704 | 877 | 957 | 736 | 909 | 989 |
| | 2/1 | U 34 | 799 | | | 831 | | |
| DC-Pro 25 | 1/1 | U 34 | 704 | 877 | 957 | 736 | 909 | 989 |
| | 2/1 | RU 56 | 850 | 893 | 973 | 882 | 925 | 1005 |

Trolley curve radii

| Trolley size | | Load capacity [kg] | Runway girder | | | |
|--------------|----------|-----------------------|----------------------|--------------------|----------------------|--------------------|
| | | | Push travel | | Electric travel | |
| | | | Flange width [mm] | Rmin [mm] | Flange width [mm] | Rmin [mm] |
| CF 5 | | 550 | 50-91 | 800 | - | - |
| U 11 DC | EU 11 DC | 1100 | 58-310 | 1000 | 58-310 | 2000 |
| U 22 DC | EU 22 DC | 2200 | 82-310 | 2000 | 82-310 | 3000 |
| U 34 DC | EU 34 DC | 3400 | 82-310 | 2000 | 82-310 | 3000 |
| RU 56 DC | EU 56 DC | 5600 | 98-310 | 2000 ¹⁾ | 98-310 | 2500 ¹⁾ |

1) From flange width 106 mm

The specified curve radii apply for normal applications.
Please enquire for frequent curve travel (e.g. in automatic installations).

Travel speeds

| Load capacity [kg] | Chain hoist Typ | Reeving | Possible cross-travel speeds in approx. ... m/min | | | | | | | | | | | | | |
|-----------------------|--|---------|---|--------------|----------|------------------|----------|------------------|----------|--------------|----------|----------|----------|--------------|----------|--------------|
| | | | V14/3 | | V12/4 | | V24/6 | | V40/10 | | | | | | | |
| | | | Trolley | Travel drive | Trolley | Travel drive | Trolley | Travel drive | Trolley | Travel drive | | | | | | |
| 80 up to 1000 | DC-Pro 1 -... up to DC-Pro 10 -... | 1/1 | | | | | U 11 DC | E 11 DC | | | | | | | | |
| 1250 | DC-Pro 10 -... | 2/1 | | | | | U 22 DC | E 22 DC | | | | | | | | |
| | DC-Pro 16 -... | 1/1 | | | | | RU 56 DC | ZBF 80 A 12/4 | | | U 22 DC | E 22 DC | RU 56 DC | ZBF 80 A 8/2 | | |
| 1600 | DC-Pro 10 -... | 2/1 | | | | | | | | | | | U 22 DC | E 22 DC | | |
| | DC-Pro 16 -... | 1/1 | | | | | RU 56 DC | ZBF 80 A 12/4 | | | U 22 DC | E 22 DC | RU 56 DC | ZBF 71 A 8/2 | | |
| 2000 | DC-Pro 10 -... | 2/1 | | | | | - | - | | | - | - | U 22 DC | E 22 DC | - | - |
| | DC-Pro 25 -... | 1/1 | | | | | U 34 DC | E 34 DC | | | RU 56 DC | ZBF 80 A | RU 56 DC | ZBF 71 A 8/2 | RU 56 DC | ZBF 80 A 8/2 |
| 2500 | DC-Pro 10 -... | 2/1 | U 34 DC | E 34 DC | - | - | - | - | - | - | | | | | | |
| | DC-Pro 25 -... | 1/1 | | | RU 56 DC | ZBF 80 A | RU 56 DC | ZBF 71 A 8/2 | RU 56 DC | ZBF 80 A 8/2 | | | | | | |
| 3200 | DC-Pro 16 -... | 2/1 | U 34 DC | E 34 DC | RU 56 DC | ZBF 80 A | RU 56 DC | ZBF 71 A 8/2 | RU 56 DC | ZBF 80 A 8/2 | | | | | | |
| 4000 | DC-Pro 25 -... | | | | RU 56 DC | ZBF 80 A 12/4 | RU 56 DC | ZBF 80 A 8/2 | RU 56 DC | ZBF 90 B 8/2 | | | | | | |
| 5000 | | | | | | | | | | | | | | | | |

E 11/E 22/E34 travel drive selection table, 220–480 V, 50/60 Hz, 3 ~

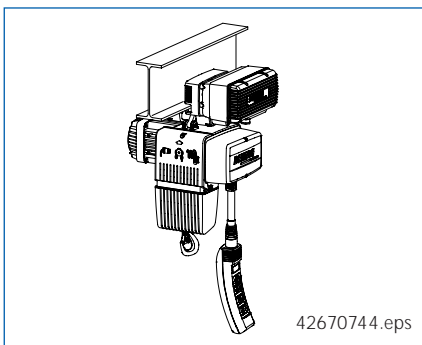

| max. displaceable weight incl. dead weight ²⁾ [kg] | Travel drive Typ | Speed at | | Possible trolleys | Max. weight [kg] |
|--|---------------------|------------------------------------|---------------------------------------|-------------------|---------------------|
| | | full load ³⁾ [m/min] | partial load ³⁾ [m/min] | | |
| 1100 | E 11 | 24/6 | 30 | U 11 | 4 |
| 2200 | E 22 | | | U 22, RF 125 | 5 |
| 3400 | E 34 | 14/3.5 | - | U 34 | 5 |

1) Possible by programming other parameters 2) Max. 1% climbing ability 3) infinitely variable up to 24m/min

See operating instructions 214 810 44 for further information.

E 22 trolley on KBK RF 125 dimensions

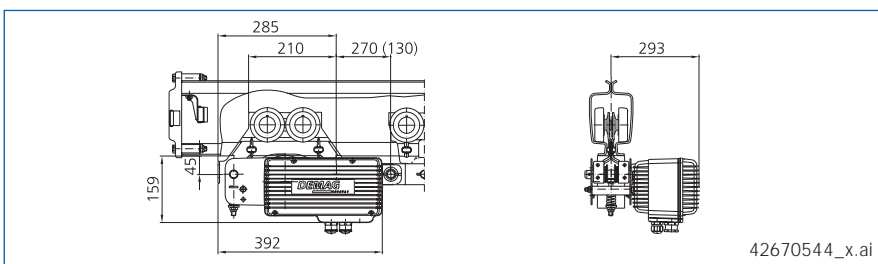

E 11/E 22/E 34 travel drive on U 11/U 22/U 34 trolley dimensions

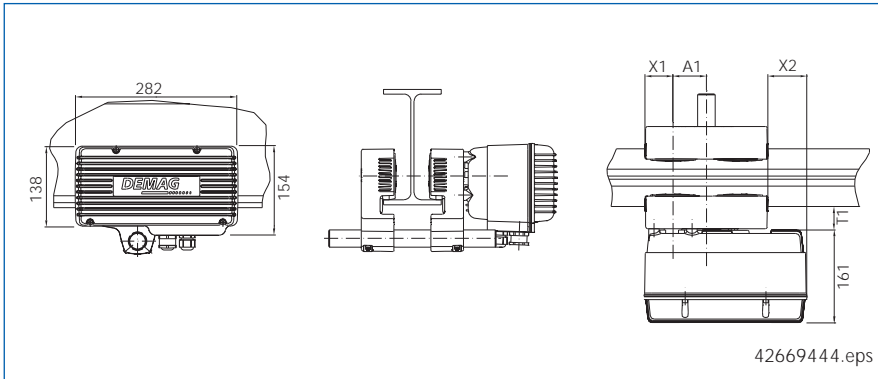

| Trolley | A1 [mm] | X1 [mm] | X2 [mm] | T1 [mm] |
|-------------|------------|------------|------------|------------|
| U 11 | 58 | 50 | 68 | 41 |
| U 22 / U 34 | 60 | 68 | 44 | 49 |

Pantograph tongs for load capacity up to 125 kg dimension table

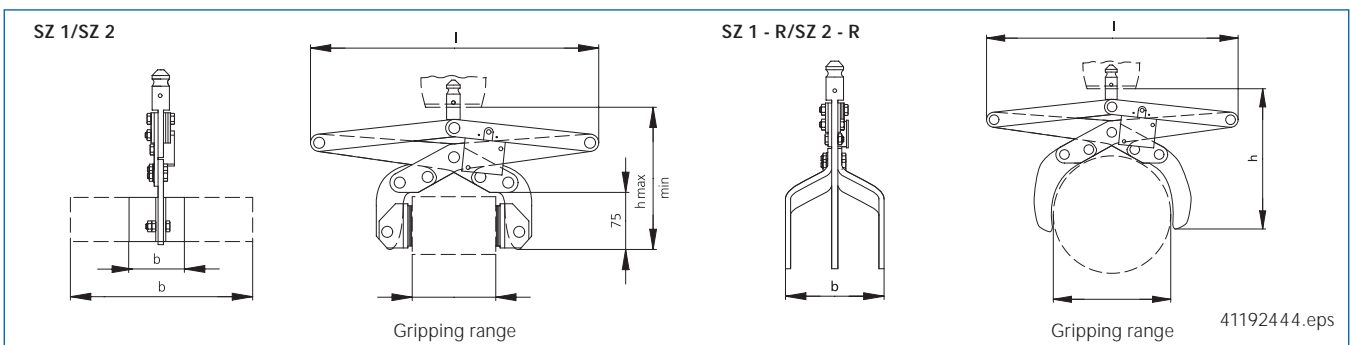

| Range | Gripping range | b | l | h min | h max | Size | Part-no.: | Weight in kg |
|------------|------------------|------------------|------------|-------|-------|------------------|------------|--------------|
| SZ 1 | 60 – 80 | 60 | 370 | 190 | 265 | SZ 1-08-1 | 265 701 44 | 3.5 |
| | 80 – 105 | | | | | SZ 1-10-1 | 565 601 44 | |
| | 105 – 130 | | | | | SZ 1-13-1 | 565 702 44 | |
| | 130 – 155 | 60 | 370 | 190 | 265 | SZ 1-15-1 | 565 602 44 | 3.7 |
| | 155 – 180 | | | | | SZ 1-18-1 | 565 703 44 | |
| | 180 – 205 | | | | | SZ 1-20-1 | 565 603 44 | |
| | 60 – 80 | | | | | 200 | 370 | |
| | 80 – 105 | SZ 1-10-2 | 565 604 44 | | | | | |
| | 105 – 130 | SZ 1-13-2 | 565 705 44 | | | | | |
| | 130 – 155 | 200 | 370 | 190 | 265 | SZ 1-15-2 | 565 605 44 | 4.5 |
| 155 – 180 | SZ 1-18-2 | | | | | 565 706 44 | | |
| 180 – 205 | SZ 1-20-2 | | | | | 565 606 44 | | |
| Ø 40 – 150 | 120 | | | | | 370 | 225 | |
| SZ 2 | 140 – 210 | 60 | 520 | 190 | 415 | SZ 2-21-1 | 565 712 44 | 4.7 |
| | 210 – 275 | | | | | SZ 2-27-1 | 565 612 44 | |
| | 275 – 340 | | | | | SZ 2-34-1 | 565 613 44 | |
| | 140 – 210 | 200 | 520 | 190 | 415 | SZ 2-21-2 | 565 715 44 | 5.4 |
| | 210 – 275 | | | | | SZ 2-27-2 | 565 615 44 | |
| | 275 – 340 | | | | | SZ 2-34-2 | 565 616 44 | |
| | Ø 100 – 300 | | | | | 160 | 520 | |

We find the right solution to meet your needs.

Demag Cranes & Components has the right hoist for every business and every load. In order to select the best product for your individual needs from the wide variety

of sizes and versions, just fill in the following fax form and send it to us or your dealer. You will promptly receive a recommended solution with the corresponding offer.

Fax service

+49 (0) 23 35 - 92 24 06

Demag Cranes & Components GmbH
Dept. 2902
Handling Technology Product Promotion
P.O. Box 67
58286 Wetter / Germany

Please send the quote to

Company

Attention of

Department

Road

Town/post code

Telephone

Telefax

E-mail

DC-Pro chain hoist

DCM-Pro Manulift

Load capacity _____ kg

Operating time per day _____ approx. hours

Lifting height _____ approx. m

Hoist speed _____ m/min

Trolley

Push-travel trolley

Electric-travel trolley

Travel speed
(for electric trolley) _____ m/min

Pillar/wall-mounted slewing jib

KBK crane construction kit
(suspension monorail/crane installation)

Girder profile dimensions _____

Operating voltage _____

Demag Cranes & Components GmbH
Handling Technology
P.O. Box 67 · 58286 Wetter / Germany
Telephone +49(0)2335 92-0
Telefax +49(0)2335 92-2406
E-mail handling@demagcranes.com
www.demagcranes.com