

Demag KBK light crane system

Overhead transport, exact positioning,
ergonomic handling



Perfect combination – Demag KBK light crane system with steel and aluminium profile sections

Track and crane installations from the Demag KBK crane construction kit have a successful track record going back many years. Countless KBK installations are in operation in almost all types and sizes of factories and workshops all over the world.

Characteristic for the system is its modular design, which makes it possible to meet a wide variety of customer requirements with ease. The high flexibility of the system enables KBK installations to be integrated easily into any production infrastructure at a later date.

The KBK light crane system offers many possibilities for handling loads quickly, safely and efficiently above the working and production level – without the need to use any of the available floor space for crane runway supports or travel paths. Consequently, all workplaces can be arranged for maximum productivity.

If required, KBK ergo components can be used to accommodate kick-up or horizontal forces, such as those which occur on cranes that have a large overhang or manipulator arms.

Besides steel profile sections, the modular system also includes aluminium profiles. KBK Aluline is the name used for a range of parts in the modular system that can be employed to create installations for convenient and smooth handling of loads weighing up to 1,000 kg.

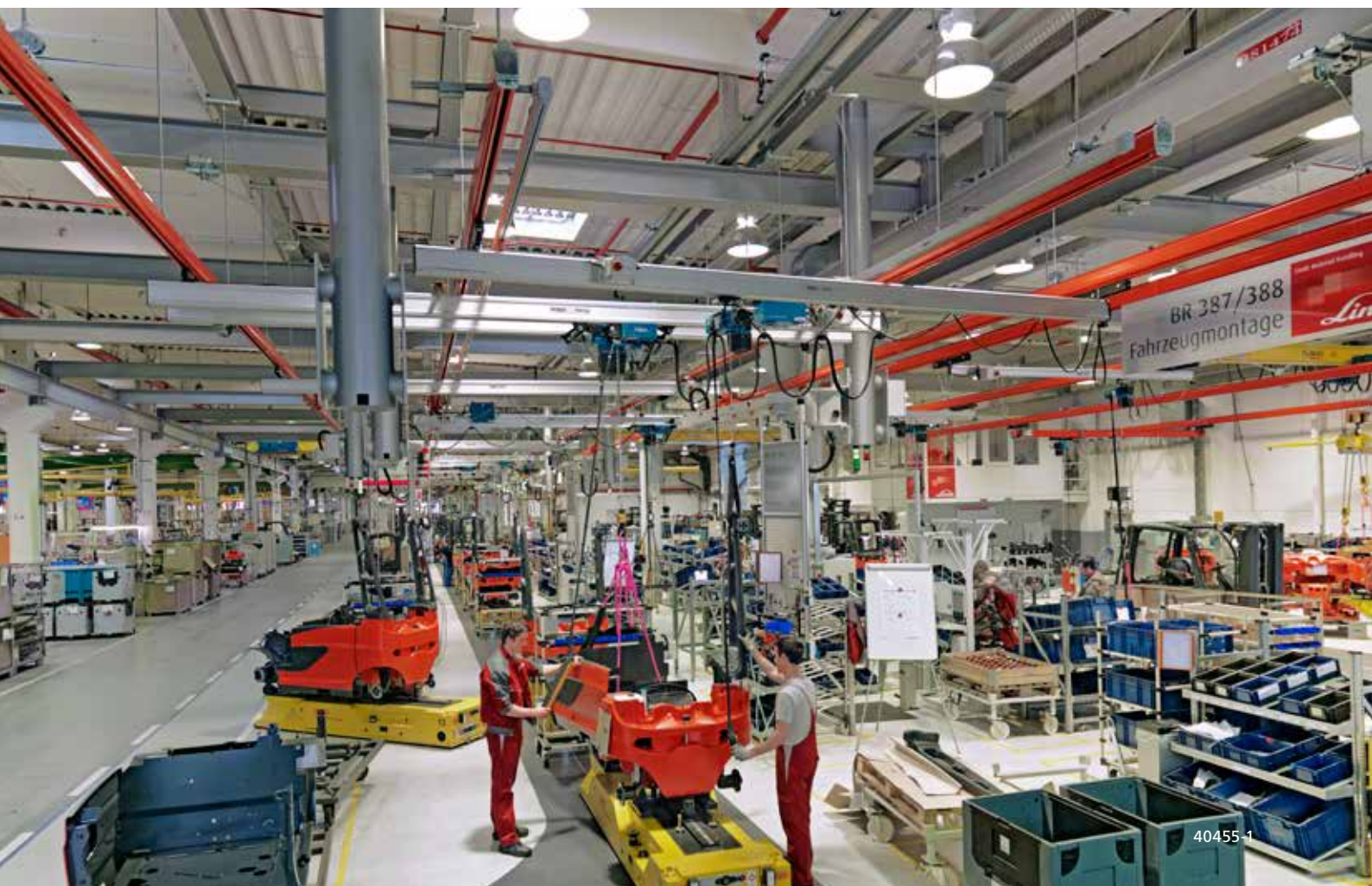

40455-1



Versatile combinations

KBK Aluline components can be simply combined with the internationally renowned KBK steel profile sections. The connecting components are compatible. They make it possible to achieve logistics solutions to meet specific needs featuring state-of-the-art industrial design and good value for money. Even easier to operate thanks to

- reduced crane deadweight
- optimum trolley travel characteristics.

For a wide variety of applications

Whether for industrial, retail or service facilities, for individual workplaces, linear transport or area-serving crane applications – KBK installations make it possible to achieve highly effective, non-accumulating transport processes to meet specific requirements. They can be built in load capacity ranges up to 3,200 kg.

Also ideal for complex material flow processes

The KBK system also meets demanding requirements for positioning accuracy and operating speeds. For this reason, it is ideally suited as a load-bearing system for complex handling systems as used in series production lines, such as in the automotive industry.

Rugged design and flexibility

Thanks to its large number of modular series components, the KBK crane construction kit can be tailored to meet individual installation and equipment requirements. The components also make it easy and cost-effective to extend and convert KBK systems as your business grows or when production processes change.

Simple installation, reliable and efficient

A further typical benefit is simple and fast assembly thanks to standardised connection dimensions and plug or bolted connections. Installations are easy to commission and maintenance work can be quickly carried out.

Made of standardised products manufactured in large series, KBK components offer:

- optimum value for money
- high functional reliability
- long service life.

Comprehensive service worldwide

We offer you comprehensive services for your KBK project:

- consultation on site
- project engineering including state-of-the-art IT support; design for special solutions
- delivery, assembly and commissioning
- Demag Service to maintain the high safety, reliability and value of your installation, including compliance with all accident prevention regulations and guidelines.

Contents

Overview	5-8	KBK ergo components	21
Suspension monorails	10-11	KBK Aluline	22-24
Single-girder suspension cranes	12	KBK Aluline components	25
Double-girder suspension cranes	13	Compact hoists	26-27
Overhung and extending cranes	14	Control components	28-29
Manipulator cranes	15	Load handling attachments	30-31
Stacker cranes, portal cranes	16	Pillar and wall-mounted slewing jibs and cranes	32-33
Crane runway support structures	17	KBK Designer planning tool	34
KBK steel components and assemblies	18-20	Enquiry form	35

Suspension monorails – for overhead material handling over long distances

Suspension monorails

- For linear transport
- To provide a direct link between pick-up and deposit points in reversing operation or a closed circuit
- Many variants possible:
 - simple, manually operated straight sections
 - complex, semi- or fully automated circuits
 - flexible routing by means of straight and curved sections, track switches and turntables.

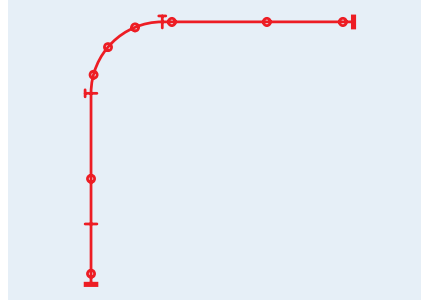

38943-1

Suspension cranes – to link production processes

Single-girder suspension cranes

- For area-serving transport
- Minimum approach dimensions
- Low deadweight
- Easily moved by hand
- Articulated connections between the crane girder and end carriages for smooth operation
- Cranes can also operate on runways that are not parallel.

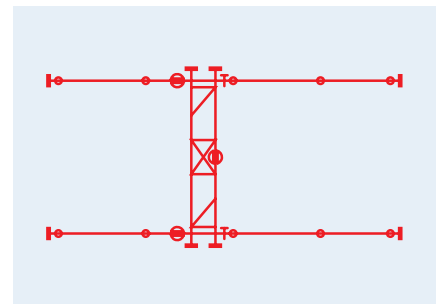
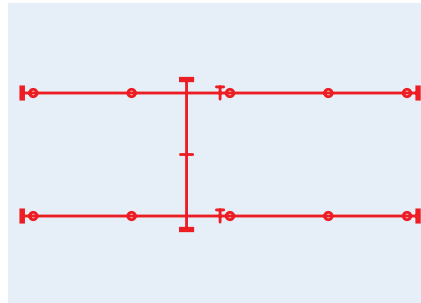

Double-girder suspension cranes

- For handling heavier loads and bridging larger spans
- Favourable installation dimensions
- Also as **manipulator cranes**, optimum design for use in state-of-the-art handling systems.
- Maximum possible hook paths by arranging the hoist between the crane girders
- Large spans can be bridged by means of multiple suspension (cranes running on more than two runway tracks).



Overhung and extending cranes – with large overhang, for extended overhead handling

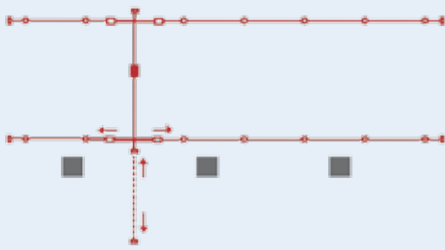

Overhung bridge cranes

- Crane girders that have an overhang extending up to 2.5 m beyond the runway span.

Extending cranes

- Variable working area: crane fitted with an intermediate girder that can be extended by up to 2.5 m on one or both sides
- Ideally suited for serving areas that are difficult to reach due to columns or supports
- Cranes to serve areas that are inaccessible due to features added at a later date, such as ventilation ducts, radiant heaters and cables.



Slewing jib cranes – workplace cranes integrated into the material flow



Slewing cranes with jibs made of KBK profile sections

- Simple traversing of the jib at any load position thanks to their low deadweight
- Comprehensive product range offers wide radius of action with high load capacities
- Can also be used as tool tracks for handling test equipment, tools, etc. as well as cable or hose suspension tracks.

Pillar-mounted slewing jibs

- Can be freely installed in almost any location.

Stacker cranes and portal cranes – ideal support at the workplace



Wall-mounted slewing jibs

- Mounted on walls, columns or machinery, require no additional floor space.

Portal cranes

- Ideal for repair and assembly work
- Travel on the floor, not rail-bound
 - Good manoeuvrability
 - Easily dismantled and re-erected.

Stacker cranes

- For storing and retrieving unit loads, containers and pallets
- Double-girder suspension cranes with special rotating stacker trolleys
- Easily moved and turned by hand.

Demag KBK light crane system –
all possible types and designs at a glance





Suspension monorails – solutions for linear transport

Suspension monorails from the KBK construction kit make it possible to implement tailored solutions for linear, overhead handling.

Highly adaptable

A wide range of components makes it possible to adapt the route precisely to meet the structural requirements of your workshop.

At the same time, all specific product and workplace requirements of your production facility are met. KBK suspension monorails

can be built to almost any design: from manually controlled straight sections to complex, semi- or fully automated closed-circuit monorail systems. Transfer between suspension monorails and adjacent suspension cranes is also possible using latching devices.

Ideal equipment carriers

For practical handling requirements, the special profiles of the KBK system are particularly suitable for applications such as equipment

carriers, e.g. for test equipment and electric and pneumatic tools.

Power supply

KBK components can also be employed for power supply lines, e.g. for cranes and other mobile equipment. The KBK system also features cable trolleys that are specially used to suspend hoses. Systems for transporting fluids, gases or a blend of energy media, such as electric current and compressed air can be built using standard components.



36147

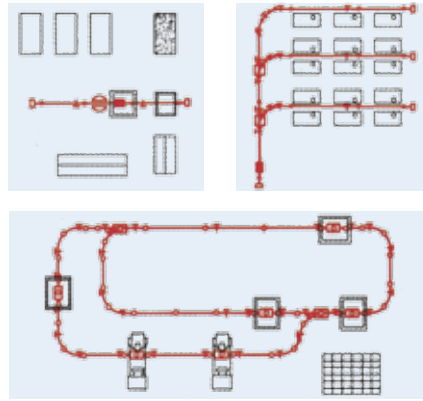

Profile selection: maximum distances between supports, headroom dimensions

KBK profile	Adjustable headroom dim. [mm]	Distance between supports for suspension monorail l_w [m]	Load capacity [kg]							
			80	125	250	500	1,000	1,600	2,000	
100	220		2.6	2.2						
I	250			3.8	2.6					
II-L	370			7.9	5.9	3.7	2.1			
II	400				8.0	5.7	3.2			
II-H	413				10.5	9.2	6.7			
III	446							3.7	3.0	

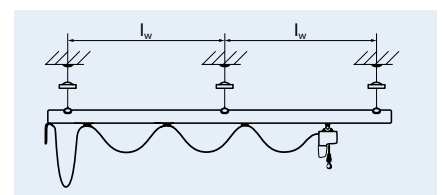

Single-girder suspension cranes – favourable dimensions, low deadweight

Single-girder suspension cranes are used for fast and reliable area-serving overhead handling and exact positioning of a wide variety of goods.

Simple and cost-effective

KBK single-girder suspension cranes can be simply suspended from the building roof or superstructure. Additional supports for the crane runway are not necessary. Even partial areas of a workshop may be easily fitted with suspension cranes at low cost, as required.

Smooth and reliable handling

Thanks to their low deadweight and smooth-running trolleys, the cranes can be easily moved by hand. Therefore, they ensure that heavy and awkward workpieces can also be handled safely and reliably.

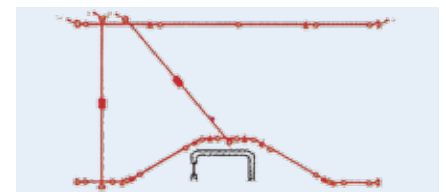
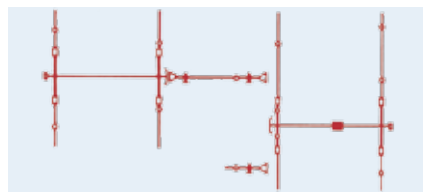

The benefits of KBK single-girder suspension cranes include latching devices that allow direct transfer of the hoist trolley between the crane and suspension monorails.

Articulated connections prevent the crane girder from snagging. Single-girder suspension cranes can also travel on angled or converging runways.

Profile selection: maximum distances between supports, crane spans, girder lengths

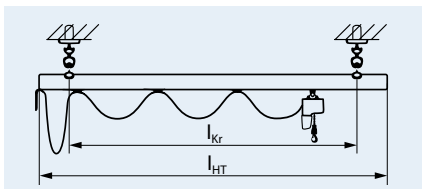

KBK profile		Load capacity [kg]						
		80	125	250	500	1,000	1,600	2,000
100	Span dimension I_{Kr}	2.5	1.8					
	Girder length I_{HT}	3.0	2.0					
I	Span dimension I_{Kr}	4.4	3.8	1.8				
	Girder length I_{HT}	5.0	4.0	2.0				
II-L	Span dimension I_{Kr}			5.9	3.7			
	Girder length I_{HT}			7.0	4.0			
II	Span dimension I_{Kr}			7.7	5.7	2.7		
	Girder length I_{HT}			8.0	6.0	3.0		
II-H	Span dimension I_{Kr}			10.5	9.2	6.6		
	Girder length I_{HT}			13.0	11.0	8.0		
III	Span dimension I_{Kr}						4.0	3.4
	Girder length I_{HT}						5.0	4.0

Double-girder suspension cranes – large lifting heights, spans and high load capacities

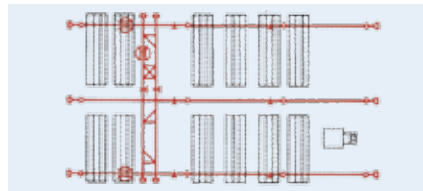
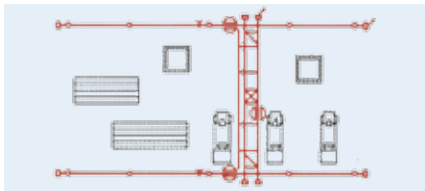

Power supply cable trolleys travel in the KBK runway or crane girder sections. If required, the control pendant can also travel independently of the hoist when fitted to a separate travel rail.

Cranes operating on several runways provide larger spans to cover extensive storage and production areas.

KBK double-girder suspension cranes also feature a low deadweight and favourable structural dimensions. In addition, the pendulating suspension largely absorbs the horizontal forces caused by starting, braking and stopping. They can even be installed in buildings of light steel construction.

Optimum lifting heights

Arrangement of the hoist unit between the two crane girders provides KBK double-girder suspension cranes with a greater useful lifting height.

Large working areas

KBK double-girder suspension cranes can also operate on several runways, thus providing large spans to cover extensive storage and production areas.

Profile selection: maximum distances between supports, crane spans, girder lengths

KBK profile		Load capacity [kg]						
		125	250	500	1,000	1,600	2,000	2,500
100	Span dimension l_{kr}	3.0						
	Girder length l_{HT}	4.0						
I	Span dimension l_{kr}	5.1	4.0	2.8				
	Girder length l_{HT}	7.0	5.0	3.0				
II-L	Span dimension l_{kr}		8.1	5.9	4.3			
	Girder length l_{HT}		10.0	8.0	5.0			
II	Span dimension l_{kr}		10.0	8.1	5.9	4.4	3.7	
	Girder length l_{HT}		12.0	10.0	8.0	5.0	4.0	
II-H	Span dimension l_{kr}		10.5	10.5	9.3	7.4	6.7	
	Girder length l_{HT}		14.0	14.0	12.0	9.0	7.0	
III	Span dimension l_{kr}					7.0	5.6	5.2
	Girder length l_{HT}					9.0	6.0	7.0

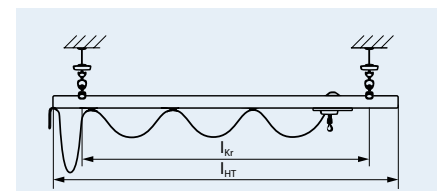

Overhung and extending cranes – large overhang, constant or variable

KBK cranes make it possible to move loads also outside the crane runway.

Overhung bridge cranes

For efficient utilisation of the available space, KBK ergo overhung cranes are fitted with crane girders that extend up to 2.5 m beyond the width of the crane runway. This enables you to reach bays added at a later date, for example.

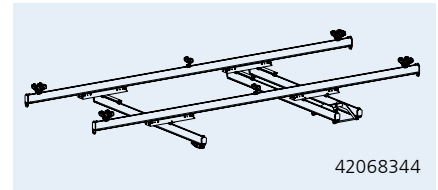

42068344

Maximum permissible overhang dimensions

Depending on profile and extension type, also dependent on the load

Model	I _A Profile		
	KBK I	KBK II-L	KBK II
Single-girder suspension crane	–	1.5 m	1.8 m
Double-girder suspension crane	1.6 m	2.3 m	2.5 m

I_A = additional length of the extension (crane trolley/hook)



39772

Overhung cranes can also handle loads below ducts, radiant heaters, pipes or similar obstacles between the wall and roof which result in the crane runway having to be positioned at a distance to the wall.

Extending cranes

KBK ergo extending cranes feature additional girders that are arranged between or beneath the crane girders.

Depending on the design, they can be extended to one or both sides beyond the width of the crane runway. These cranes can also be used for precisely lifting and positioning loads in almost inaccessible areas, such as between pillars and columns.



37701_2

Maximum permissible overhang dimensions

Depending on profile and extension type, also dependent on the load

Model	I _A (max) Profile	
	KBK II-L	KBK II
A1/1	1.5 m	1.8 m
B2/1	1.5 m	2.0 m
B2/2	2.3 m	2.5 m

I_A = additional extension length (extension point/hook)

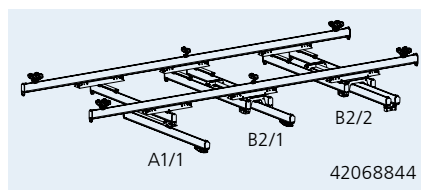
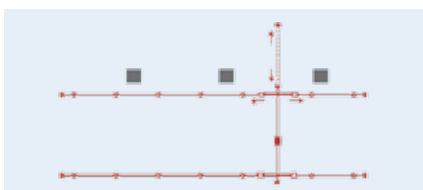

42068844

Manipulator cranes – optimum ergonomic load handling

Double-girder suspension cranes can also be designed as manipulator cranes using KBK ergo components. They can be designed to meet the exact needs of the relevant loads, processes and production conditions. They make it possible to

- move workpieces and subassemblies into the most favourable positions for the relevant process,
- serve workplaces, machinery and installations from any direction,
- perform operations outside the suspension area, thus increasing the operating range.

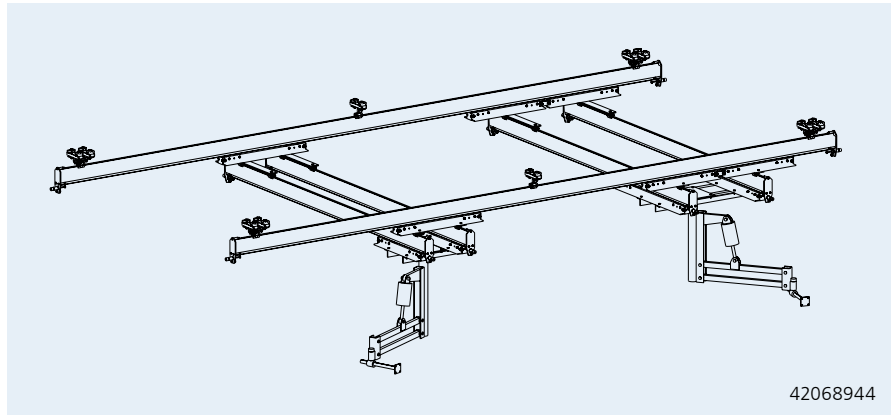

Innovative and ready to meet tomorrow's needs

Manipulator cranes are built using selected KBK ergo components. They feature the ability to accommodate kick-up forces.

These installations offer outstanding positioning accuracy and high operating speeds. In this way, they form the basis for optimum ergonomics and efficient workplace design.

Fast upgrade

If you already have double-girder suspension cranes from the KBK crane construction kit, they can be easily and quickly modified with KBK ergo components to become manipulator cranes.

Portal and stacker cranes – specialised handling equipment for stores and factories

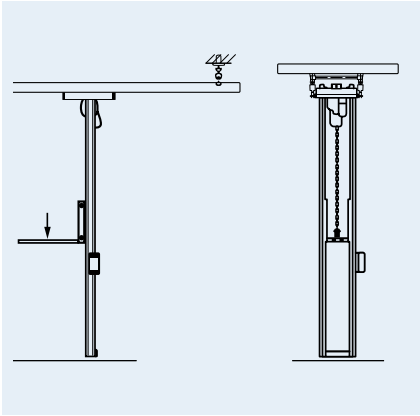

wherever unit loads, containers or pallets weighing up to 500 kg have to be transported, sorted and stored.

The stacker crab can be fitted with forks, prongs, gripper tongs or other load handling attachments in accordance with the specific load handling requirements. The mast with its trolley is easily moved by hand and can rotate through 360°.



Stacker cranes

Stacker cranes make it possible to complete all tasks in one operating cycle without the need for ladders, order-picking trolleys or similar equipment.

They mainly consist of a KBK double-girder suspension crane and a special stacker trolley. And they are used

Portal cranes

Portal cranes with load capacities up to 1,000 kg can be used wherever a suspension crane is not cost-effective or cannot be installed. They run on solid, even surfaces and can be manoeuvred easily in all directions, which often makes them ideal for repair and assembly work.

A particular advantage in many applications is that KBK portal cranes can be easily dismantled, transported and quickly re-erected elsewhere. The crane girder span can also be adjusted.



Crane runway support structures – free-standing solutions to meet individual needs

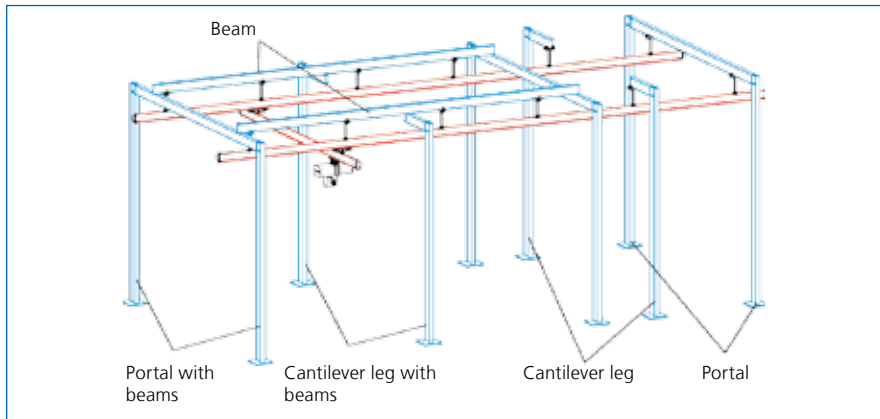

KBK installations can even be built in facilities where the workshop ceiling and roof structures cannot bear loads. Support structures tailored to meet your needs can be built quickly and efficiently using a range of standardised steel superstructure components. The required crane runways or suspension monorails can be attached direct to the supports or beams.

Model	KBK suspension	Profile
Cantilever leg	direct	HE-A (leg), IPE (cantilever arm)
Cantilever leg with beam	on the beam	HE-A (leg), HE-A (cantilever arm), IPE (beam)
Portal	direct	HE-A (leg), IPE (crossbar)
Portal with beam	on the beam	IPE (leg), IPE/HE-A (crossbar), IPE (beam)

All supports are supplied with foot plates that are dimensioned according to the design. They can be secured to the floor using foundations featuring anchor rods or by means of anchor bolts.



As an alternative to conventional steelwork, the Hilti MI rail system can be used to create a support superstructure for installations with a load capacity up to 500 kg. This system is also of modular design, can be adapted to meet your specific needs and is also easy to assemble.

Hilti MI rail system as a support superstructure for a KBK single-girder suspension crane

KBK steel components and assemblies – maximum flexibility for greater planning freedom

Profile sections

The basic elements are special cold-rolled steel track sections available in six different sizes:

- KBK 100 Load capacity up to 125 kg
- KBK I Load capacity up to 500 kg
- KBK II-L Load capacity up to 1,000 kg
- KBK II Load capacity up to 2,000 kg
- KBK II-R KBK II with internal 5-pole conductor line
- KBK II-H Reinforced KBK II profile section, for distances between suspensions of more than 6 m and profile section loads up to 1,200 kg
- KBK II-H-R KBK II-H with internal 5-pole conductor line
- KBK III Outside-running profile section with 3,200 kg load capacity
- KBK III Available with internal with DEL conductor line with up to 10 poles

For each size, all standardised components and assemblies, such as straight and curved track sections, track switches, turntables, drop sections, etc., have the same uniform joint dimensions. Self-centring plug-in and bolted connections allow them to be easily assembled in any combinations.

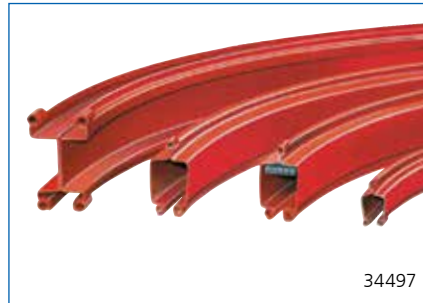

Straight and curved sections

Profile sections for loads weighing up to 2,000 kg are hollow track sections with protected inside running surfaces.

The KBK III profile of outside-running design is available for loads weighing up to 3,200 kg. KBK II, KBK II-H and KBK III profile sections can also be supplied with integrated conductor lines.



Suspensions

The profile sections are suspended so as to allow pendulation, which prevents bending stresses in the support superstructure and minimises horizontal forces.

Plastic shells in the ball joints reduce impacts and noise. They also reduce maintenance to a minimum. The track height can be easily and precisely adjusted by means of the threaded suspension rods that connect the ball joint heads.

Different profile section sizes can be used for single and double-girder suspension crane runways and girders. All components are protected against corrosion – they are either finished with a coat of paint, galvanised or electro-coated.



Nine profile sections in six sizes:
KBK steel profile sections at a glance

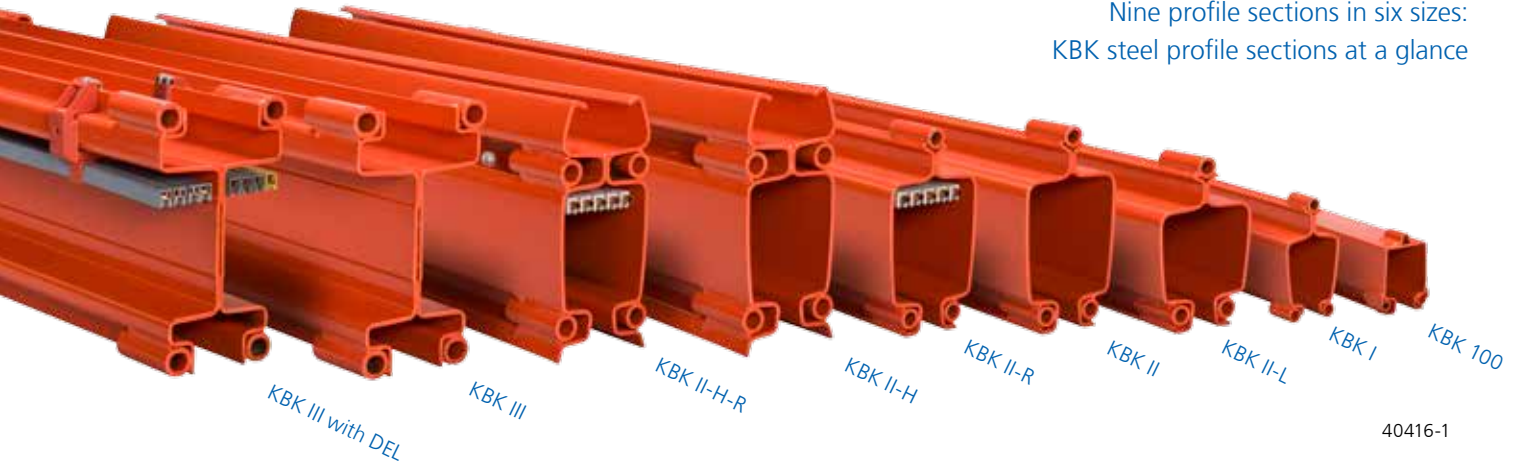

40416-1

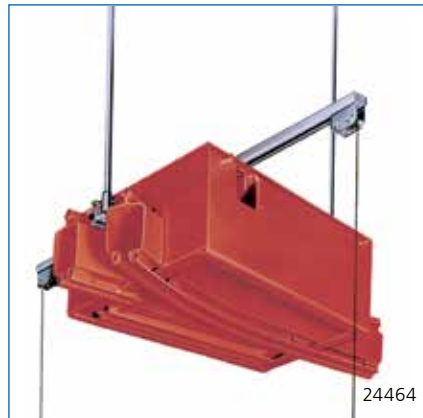

24464



24463

Rail joint

One of the strengths offered by the KBK II-H profile section is its completely rigid rail joint. The rail joint can be subjected to a full load, regardless of the position of the track suspension. Consequently, there is no need for special profile section lengths due to predefined distances between suspensions. This results in price advantages and provides for greater planning freedom.

Track switches

Track switches of compact, enclosed design are used as branching or converging components in the material flow. They can be supplied for manual, electric or pneumatic switching for semi- or fully automatic control.

Turntables

Turntables make it possible to change direction in a minimum of space. Integrated mechanical locking devices prevent trolleys from leaving or entering the turntable section while it is turning. Turntables can be manually or electrically operated.





Friction wheel travel drives

Fitted with large friction wheels that have a high friction coefficient, these travel drives ensure that the drive forces are transmitted efficiently. Springs provide constant pressure between the drive wheels and the running surface of the track. Therefore, the connection between the friction wheel and the track does not depend on the position and weight of the suspended load. Friction wheel travel drives are quiet in operation.

Various drives are available depending on the load and the required travel speed. In addition, variable-speed travel drives and a pneumatic drive to support the movement of handling devices can be supplied.

Trolleys

Fitted with bearing-mounted plastic wheels, push travel trolleys are easy to move. The rollers are maintenance-free and designed for a long service life. They effectively absorb all impacts and are silent-running.

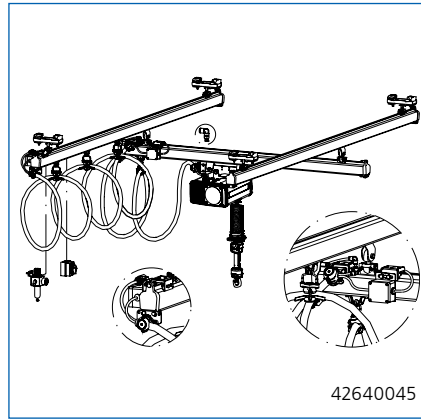

Power supply

Flat cables are preferably used to supply power. Profile sections with internal conductors are used for power supply for

- more than two cranes on one crane runway
- more than two travelling hoists on a suspension monorail
- closed-circuit monorail systems
- tracks with track switches, turntables, latching devices and drop sections.

KBK II-R and KBK II-H-R profile sections have 5-pole conductors, while KBK III has up to 10 individual conductor lines, which are rugged and require little maintenance. Compressed air and electric power are frequently required to operate handling equipment. They can be supplied by means of a smooth-running trailing helical cable system.



Drop sections

Drop sections are mainly used in closed-circuit tracks to pick up and deposit loads at predetermined positions. This eliminates the need for hoist units. The trolley is mechanically locked in place when lowered in the drop section. Mechanical locks in the track stop other trolleys on either side of the drop section.

Latching device

Suspension monorails and single-girder suspension cranes can be connected by means of latching devices. This arrangement allows the travelling hoist to transfer from the crane to the suspension monorail. When disengaged, the crane travels past the end of the monorail without any mechanical contact.



KBK ergo components – sub-assemblies for overhung, extending and manipulator cranes

KBK ergo components can be used to build cranes that have to accommodate kick-up forces. This may be the case for overhung, extending and manipulator cranes.

Suspensions

Fitted with integrated damping elements, KBK ergo suspensions absorb energy from various directions.

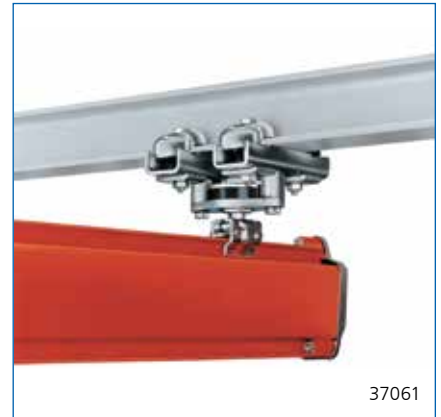

End carriages

End carriages provide for improved rigidity and increased positioning accuracy.



Trolleys

KBK ergo trolleys feature articulated axles and correspondingly dimensioned rollers for lateral guidance. They reliably absorb any upward and lateral forces and moments.

End caps

Special shock absorbers are required on rigid systems with uncompensated loads. Shock absorbers integrated in the end caps dissipate the energy transmitted by impact loads to all components and assemblies as well as the support superstructure.

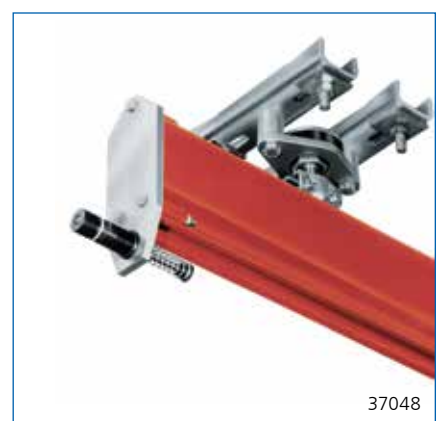

Crab frame

The specially developed crab frame is a rugged, high load bearing system for mounting specially equipped hoists and manipulators.

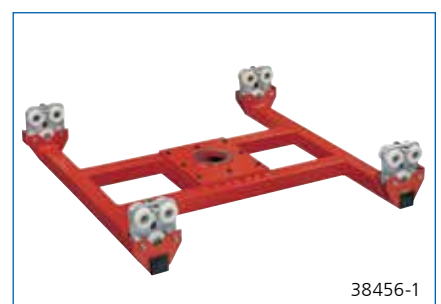

KBK Aluline – simple ergonomic handling

KBK Aluline can be used to construct both single and double-girder suspension cranes for area-serving transport requirements as well as straight suspension monorail systems for direct connections between workplaces. Standard installations are suspended from articulated fittings.

KBK Aluline ergo components are used for overhung and manipulator cranes.

Combination with steel sections

Compatibility within the KBK system permits a large number of possible combinations of steel and aluminium fittings.

profile sections within an installation. All suspension components and trolleys of the KBK Aluline range are based on components used for the Demag KBK steel system, which is successfully used in thousands of installations all over the world.



38450-8



39034-3



38450-10

Outstanding benefits of KBK Aluline:

- Technically advanced system that is easy to assemble
- Compact dimensions and low deadweight
- Can be integrated with ease and extended to provide versatile solutions
- Can also be combined with steel profile sections
- State-of-the-art industrial design thanks to anodised aluminium profile surfaces.



Smooth and reliable handling

Thanks to their low deadweight and smooth-running trolleys, the cranes can be easily moved by hand. This ensures that heavy and awkward workpieces can also be handled safely and reliably.

KBK Aluline suspension cranes can be simply suspended from the building roof or superstructure. Additional supports for the crane runway are then not necessary. In this way,

sections of a factory building can also be served cost-effectively by cranes:

- single-girder suspension cranes for smaller loads
- double-girder suspension cranes for higher loads and larger spans.

The crane installations can be easily moved by hand as standard. Electric or pneumatic travel drives can be supplied as options.

Compared to **single-girder cranes**, **double-girder cranes** have more favourable installation dimensions and provide the maximum possible hook paths thanks to the arrangement of the hoist between the crane girders. In combination with KBK Aluline ergo components, they are also ideally suited as **manipulator cranes** for the use of state-of-the-art handling systems.

Suspension monorails

Profile	Lifted load G_H [kg]				
	80	125	250	500	1,000
Aluline 120 l_w [m]	5.1	4.2	3.1	2.0	
Aluline 180 l_w [m]		8.0	6.5	4.6	2.8

l_w = Distance between suspensions

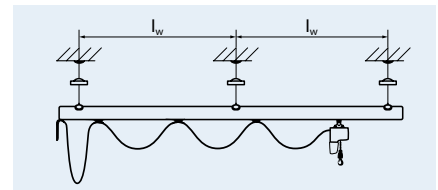

Single-girder suspension cranes

Profile	Lifted load G_H [kg]				
	80	125	250	500	1,000
Aluline 120 l_{Kr} [m]	4.8	3.9	2.9		
l_{HT} [m]	5.0	4.0	3.0		
Aluline 180 l_{Kr} [m]	7.9	7.9	6.3	4.5	2.9
l_{HT} [m]	8.0	8.0	7.0	5.0	3.0

l_{Kr} = Crane span dimension

l_{HT} = Crane girder length

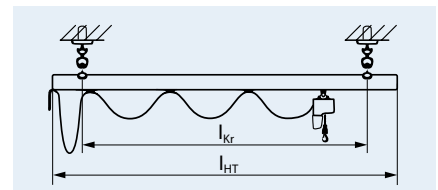

Double-girder suspension cranes

Profile	Lifted load G_H [kg]				
	80	125	250	500	1,000
Aluline 120 l_{Kr} [m]		5.5	4.2	3.1	
l_{HT} [m]		7.0	5.0	4.0	
Aluline 180 l_{Kr} [m]			7.9	6.3	4.6
l_{HT} [m]			8.0	8.0	5.0

l_{Kr} = Crane span dimension

l_{HT} = Crane girder length

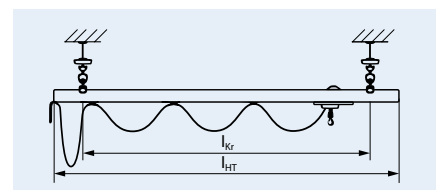

KBK Aluline components – for installations with reduced deadweight

Simple and reliable assembly

The KBK Aluline crane construction kit enables you to design almost any overhead suspension crane or monorail system. The track sections measuring up to 8 m in length are simply and reliably connected. They can be assembled quickly and precisely by hand also as a “do-it-yourself” kit.



Profile sections

The basic element is a profile section rail that is available in two sizes. The unique matt silver look of anodized aluminium gives KBK Aluline profile sections a lightweight appearance. Cavities in the upper and lower parts of the track sections ensure great mechanical rigidity. Slots along the track sections make it easy to mount attachments.



Trolleys

The trolleys run smoothly and quietly on plastic travel wheels mounted in anti-friction bearings that are lubricated for life. KBK trolleys feature an articulated, torque-free load connection. KBK ergo trolleys can also accommodate kick-up forces.



Joint connections

Matching interface dimensions and precise bolted connections enable KBK Aluline profile sections to be assembled quickly and easily.

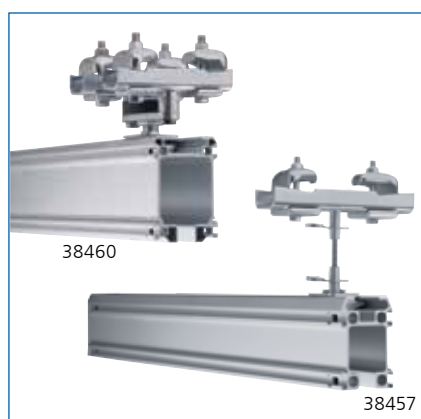

Suspensions

Standard systems are fitted with KBK suspensions. Equipped with articulated joints, they provide a low-torque connection to the support superstructure. Special systems designed to accommodate offset loads are fitted with KBK ergo suspensions.

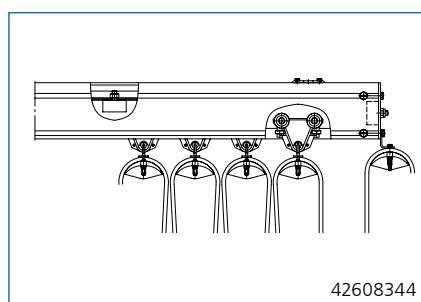

Power supply

Highly flexible and cold-resistant flat cables are individually suspended from cable sliders or cable trolleys in groups.

Demag compact hoist units – chain hoists and rope winches for every application

Demag compact hoist units offer a wide variety of load capacities, speeds and features for a maximum of safety and reliability. They can be used to meet individual application requirements in industry, workshops and the trade sector. Compact hoists are supplemented by a wide range of load handling attachments for every application.



DCM-Pro/DCMS-Pro

The **Demag DC-Pro chain hoist** is available in two versions for loads weighing up to 5,000 kg: as the DC-Pro with a DSC control pendant and as the **Demag DCM-Pro Manulift** for quickly handling loads with only one hand. Both versions feature a wide range of integrated standards, offer outstanding ease of operation and maintenance, high standards of safety and optimum efficiency.

Thanks to the infinitely variable speed control of the **Demag DCS-Pro chain hoist**, sensitive parts can be lifted, lowered more gently and carefully and positioned with great precision.

Hoist motions can be performed much more quickly thanks to the higher lifting speed in the partial load range due to their Pro-Hub function.

The variable speed type is also available as the **DCMS-Pro Manulift** for single-handed operation.

The **Demag DC-Com chain hoist** is an inexpensive, high-quality entry-level variant with basic features, just right for everyday use for loads weighing up to 2,000 kg.



39285-1

D-SH with rocker switch and quick-release coupling



38988-2

D-SH with manual-force control and quick-release coupling (D-Grip)



39285-3

D-SH with rocker switch and C-hook

The **D-SH SpeedHoist rope winch** is specially developed for fast load-handling applications. This makes it ideal for fast transfer sequences in series production or in order-picking operations, for example. Available in two load capacities: 80 kg and 160 kg.

D-Grip and rocker switch control handles facilitate precise, extremely light and fatigue-free control. The operator's hand motions are translated by the D-Grip into exact lifting movements at infinitely variable speeds.



39286-6

Demag components – for manual and automatic controls

Installations made from the Demag KBK crane construction kit can either be fitted with manual controls or semi- or fully automatic control systems. All components correspond to the latest design and accident prevention regulations and meet the requirements of international rules and regulations.



DSK, DST and DSE control pendants

The ergonomic design and sloping housing facilitate fatigue-free operation and permit operators to work in a natural and comfortable position.

DST and DSE control pendants offer a wide variety of switch combinations for hoists, crabs and cranes. They can also be used to control machinery and installations.



DRC-MP radio control

The radio control system is used for the convenient, wireless control of KBK installations and other cranes and hoists. It is also suitable for industrial doors, machinery and other installations and for controlling up to a maximum of three motion axes.

- Optional pushbutton or joystick transmitter units
- Impact and temperature-resistant housing design
- Reliable data transmission.



Dematik IR infrared remote control

The Dematik IR infrared system can be used for wireless control of KBK installations as well as other facilities and machinery. The hand-held transmitters are available in three sizes.

- Ergonomic transmitter enclosure with carrier
- Range limited to approx. 40 m
- Simple upgrade.



Frequency inverters

Frequency inverters that can be adapted to specific operating sequences make it possible to implement infinitely variable speed control of drives, for example.

Integrated electrical equipment

Arranged directly on the units to be controlled and featuring plug-and-socket connectors, integrated electrical equipment guarantees fast and easy connection of control units and cables. Integrated electrical equipment is also subjected to punishing long-term shock and vibration resistance tests as well as function tests at varying temperatures and under various climatic conditions.

PLC programmable logic control automation systems

These systems make it possible to implement solutions for any materials handling automation requirements. Based on compact modules, existing control systems can be extended at any time. Operating sequences can also be visualised.

Load detectors

Optional electronic load detectors on hoist units provide overload protection for maximum safety and efficient utilisation. Additional load summation and digital load displays can be added.

Pulse generators

Pulse generators integrated into electric motors provide countable signals for measuring speed and rotation in both directions. The units can be automated.

Demag load handling attachments – versatile and efficient

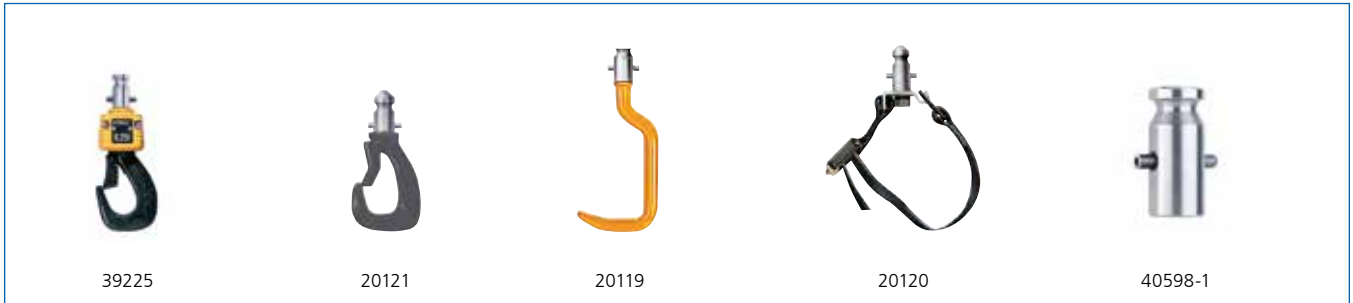

Mechanical load handling attachments

Grippers, load pins, load forks, load hooks and tongs are mainly employed as mechanical load handling attachments. They are chiefly combined with versatile load lifting modules, e.g. Manulift or rope balancer units.

They are connected by means of a quick-release coupling. The load handling attachments are fitted with a connecting pin with a swivel lock, which snaps into the quick-release coupling.



Gripping devices as well as tongs are usually based on a scissor mechanism. Fitted with a variety of jaws, PGS parallel grippers can be used for many applications, e.g. for handling shafts, containers or bins.

Load handling magnets

The range of load handling magnets includes:

- DPMN compact permanent magnets, suitable for flat and round materials, operation independent of the mains
- DBM 34/68 rectangular battery magnets, operation independent of the mains
- R15–30 electro-magnets, round single magnets for loads weighing up to 1,400 kg, with integrated rectifier and switch as standard.

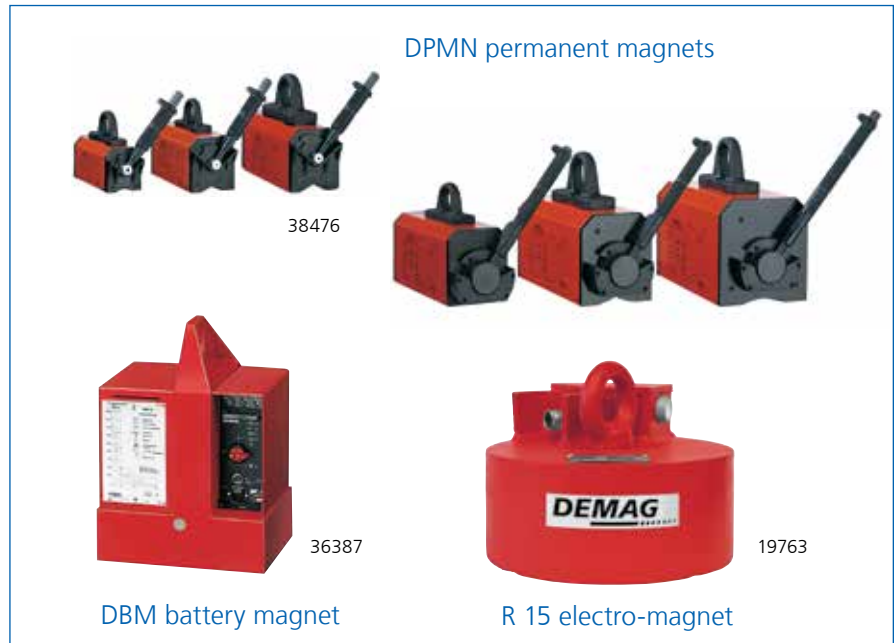

Vacuum load handling attachments

Vacuum load handling attachments can be operated by compressed air via injectors and electric vacuum pumps or fans. The latter operate with comparatively low under-pressure, however, with high volume flows and are particularly suitable for handling air-permeable workpieces such as textiles and cartons, for example.

Available options:

- devices for supplying compressed air to suction pads for rapid deposit of loads
- safety circuits and underpressure reservoirs to maintain the suction energy in the event of a power failure.

Demag slewing jib cranes – efficient workplace units

Pillar and wall-mounted jib cranes help to cut setting-up and idle times and reduce unnecessary waiting times. With a wide range of sizes and designs, these cranes can be adapted to provide the optimum solution for the most varied requirements in terms of load capacity, slewing range, outreach and features – even including cranes with two jibs.

The main characteristic of all variants is their low jib deadweight and correspondingly large outreach and high load capacity. Demag jib cranes are supplied complete with the electrical equipment and hoist including the corresponding trolley; they can also be supplied without these components, if required. Special hook path dimensions can

be achieved by means of longer masts or pedestals. Kits are also available to anchor the mast to foundations or existing workshop floors.

Pillar-mounted slewing jibs

Slewing range 270°/300°

Load capacity [kg]	Outreach [m]*									
	2	3	4	5	6	7	8	9	10	
80										
125										
250										
500										
1,000										
1,600										
2,000										

Pillar-mounted slewing cranes

Slewing range n x 360°

Load capacity [kg]	Outreach [m]*											
	2	3	4	5	6	7	8	9	10	11	12	
80												
125												
250												
500												
1,000												
1,600												
2,000												
2,500												
3,200												
4,000												
5,000												
6,300												
8,000												
10,000												

Wall-mounted slewing jibs

Slewing range 180°/270°

Load capacity [kg]	Outreach [m]*											
	2	3	4	5	6	7	8	9	10	11	12	
80												
125												
250												
500												
1,000												
1,600												
2,000												
2,500												
3,200												
4,000												
5,000												
6,300												
8,000												
10,000												

- Type KBK 100 – slewing range = 270°. Classification to H2B3. See technical data sheet 203 565 44.
- Type KBK I/II – slewing range ~300°. Classification to H2B3. See technical data sheet 203 565 44.
- Type D-AS 270 – slewing range ~270°. Classification to H2B3. See technical data sheet 203 502 44.

- Type D-GS 360 – manual slewing. Classification to H2B2. See technical data sheet 203 502 44.
- Type D-TS 360 – manual slewing or with electric slewing drive. Classification to H2B2. See technical data sheet 203 502 44.
- Type D-MS 360 – manual slewing or with electric slewing drive. Classification to H2B3. See technical data sheet 203 502 44.

- Type KBK 100 – manual slewing. Slewing range ~270°. Classification to H2B3. See technical data sheet 203 565 44.
- Type KBK I/II – manual slewing. Slewing range ~270°. Classification to H2B3. See technical data sheet 203 565 44.
- Type D-AW 180 – manual slewing. Slewing range ~180°. Classification to H2B2. See technical data sheet 203 502 44.
- Type D-GW 180 – manual slewing or with electric slewing drive. Slewing range ~180°. Classification to H2B2. See technical data sheet 203 502 44.

* Intermediate lengths possible



39043-1



39342-1



40172-5

Pillar-mounted slewing jibs and cranes

These cranes can be installed almost anywhere. They are completely free-standing and are ideal as workplace cranes as well as for outdoor storage areas, loading ramps and for workshops in which other handling equipment cannot be used for structural reasons.

The pillar requires only a minimum footprint. Even where only little headroom is available, pillar-mounted jib cranes provide maximum hook paths.

Wall-mounted slewing jibs

They require no floor space as they are mounted on load-bearing concrete walls or pillars as well as machinery and installations. Thanks to their braced design, the jibs of KBK wall-mounted jib cranes have a particularly low deadweight and can be easily moved with the load by hand.



40050-6



39635

KBK Designer planning system – fast and simple planning

You can find all important facts and information on the KBK light crane system at www.demag-designer.com.

Our online KBK Designer tool provides you with project engineering support for KBK crane installations made of steel and aluminium and for slewing jibs and cranes. You can download corresponding CAD files and integrate them into your design drawings. The intuitive user interface will help you to find the right solution to meet your needs quickly and easily. You can then send us your specific enquiry at the click of a mouse button.

Always at your service

If you have any questions or want further information, please use the fax form on the opposite page or contact one of our experienced sales engineers direct – visit www.demagcranes.com or call +49 (0) 2335-2922 to find the nearest contact in your area.



Demag Cranes & Components GmbH
KBK Product Promotion
PO Box 67

58286 Wetter, Germany

Fax enquiry: +49 (0) 2335 92-2406

Email: handling@demagcranes.com

Please send a quotation/the information to:

Company

PO Box/Street

Town/post code

Contact

Telephone/extension

Fax

Email

Project engineering for KBK installations

I am interested in

- | | | |
|--|--|--|
| <input type="checkbox"/> Suspension monorails | <input type="checkbox"/> Overhung cranes (KBK ergo) | <input type="checkbox"/> Stacker cranes |
| <input type="checkbox"/> Single-girder suspension cranes | <input type="checkbox"/> Extending cranes (KBK ergo) | <input type="checkbox"/> Portal cranes |
| <input type="checkbox"/> Double-girder suspension cranes | <input type="checkbox"/> Pillar-mounted slewing cranes | <input type="checkbox"/> Crane runway support structures |
| <input type="checkbox"/> Manipulator cranes (KBK ergo) | <input type="checkbox"/> Wall-mounted slewing jibs | |

I require

- | | | |
|--|------------------------------------|--|
| <input type="checkbox"/> Telephone contact | <input type="checkbox"/> Quotation | <input type="checkbox"/> Detailed information on _____ |
|--|------------------------------------|--|

Details of the planned installation

Weight of the load _____ kg Description of the load _____

Workshop dimensions	Crane girder length	_____ mm
Width _____ mm	Manipulator crane outreach length	_____ mm
Height _____ mm	Overhung crane overhang length	_____ mm
Monorail/crane runway length	Extending crane intermediate girder length	_____ mm
_____ mm	Pillar-mounted crane jib length	_____ mm
	Wall-mounted crane jib length	_____ mm
	Required hook path	_____ mm

Additional information _____

